

IN8449

ULTI Rack+

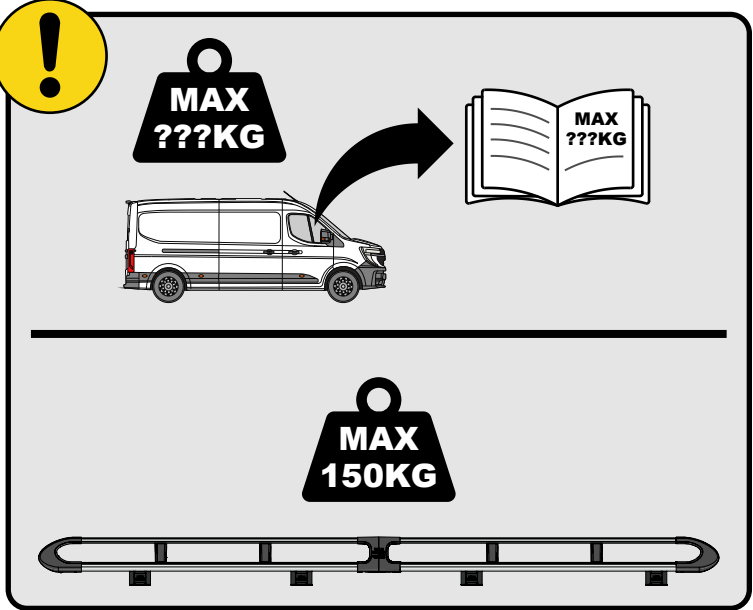

 Customercare@van-guard.co.uk
UK +44 (0) 1392 368 351

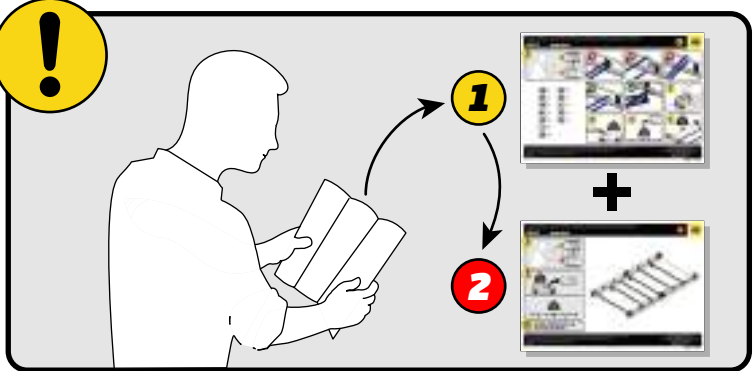

This FITTING INSTRUCTION is the property of VAN GUARD ACCESSORIES LTD. and must not be used for manufacturing purposes, copied nor communicated in any way to third parties without written permission from VAN GUARD ACCESSORIES LTD.
IN8449_A (CN:NR)

Van Guard Accessories Ltd
Fair Oak Close, Exeter Airport Business Park,
Exeter, Devon, EX5 2JL
www.van-guard.co.uk

THIS INSTRUCTION COVERS THE FOLLOWING MODELS - CHECK YOU ARE FITTING THE CORRECT MODEL BEFORE PROCEEDING

VGUR-303

Nissan Interstar: 2025 on
Renault Master: 2025 on
L2H2 (MWB)
Twin Rear Doors

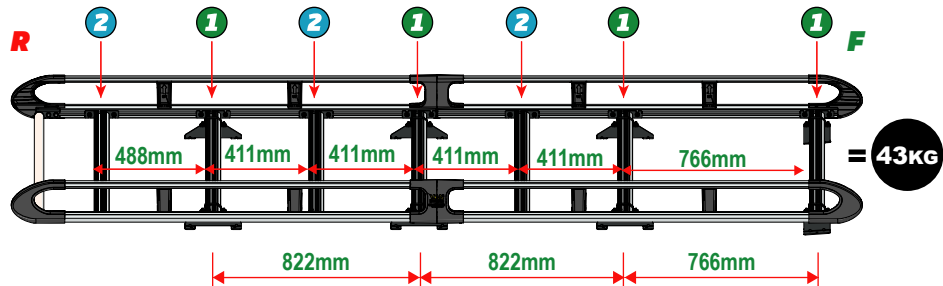
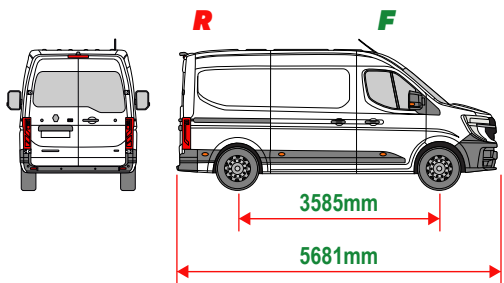

SUPPLIED COMPONENTS - CHECK ALL PARTS ARE PRESENT AND CORRECT BEFORE PROCEEDING (1 OF 2)

TOOLS REQUIRED

10MM X1



13MM X2

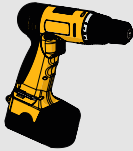

Ø4 & Ø9

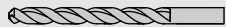
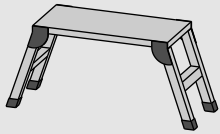

AS3543 X2
(3200 / A)

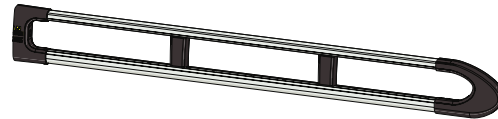

MA6118 X14



FX4241 X32

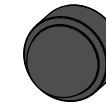

ME1622 X3

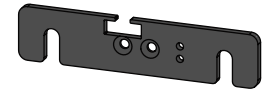

AS3542 X2
(3200 / B)

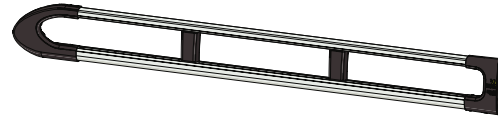

FX4008 X1



MA6145 X1

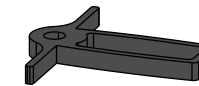

ME1623 X3

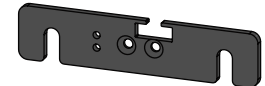

ME1628 X7
(1554mm)

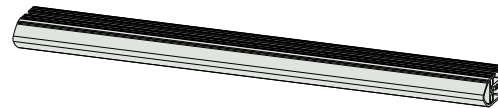

FX4001 X2
(M8X40)

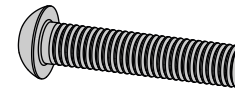

FX4235 X28
(M5X25)



ME0203 X10

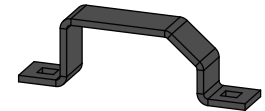

AS3160 X1
(1540mm)

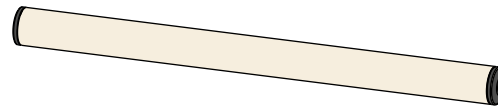

MA6007 X4



FX4248 X1
(T25)

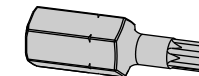

MA6065 X10

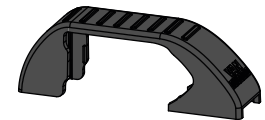

AS3590 X1

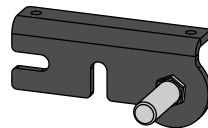

MA6093 X14

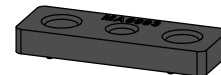

FX4239 X32
(M8X20)

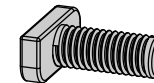

ME1620 X4

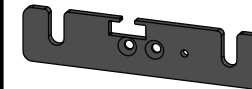

FX4016 X20
(M6)



AS3591 X1

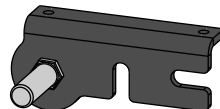

ME0316 X14

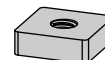

FX4240 X32
(M8)



ME1621 X4

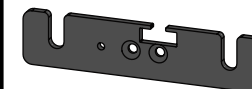

FX4042 X20
(M6X16)

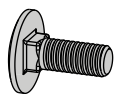

SUPPLIED COMPONENTS - CHECK ALL PARTS ARE PRESENT AND CORRECT BEFORE PROCEEDING (2 OF 2)

ME2500 X6

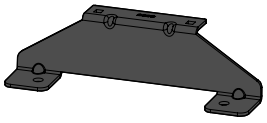

FX4014 X14

(RUBBER)



ME2542 X2

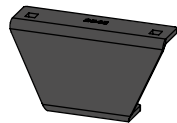

ME2501 X14

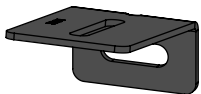

FX4040 X14

(M8)

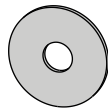

FX4072 X4

(M8)

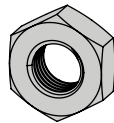

ME2515 X1

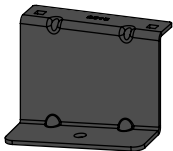

FX4011 X20

(M8)



FX4019 X4

(M8)

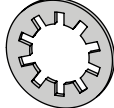

ME2516 X1

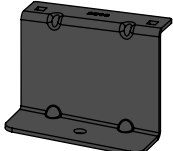

FX4318 X12

(M8)

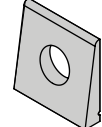

MA6060 X2

(M8)

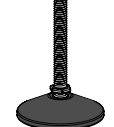

MA6269 X12

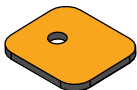

FX4319 X6

(M8x100)

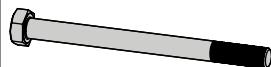

MA6268 X2



FX4028 X14

(M8x25)

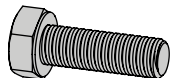

01

1L

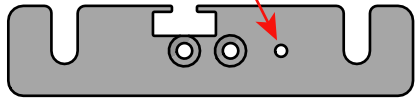

X4

1R

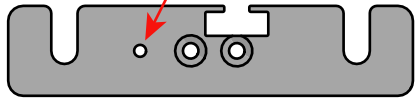

X4



2L

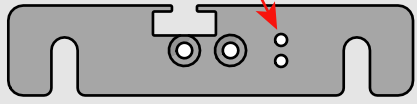

X3

2R

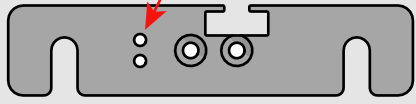

X3

02

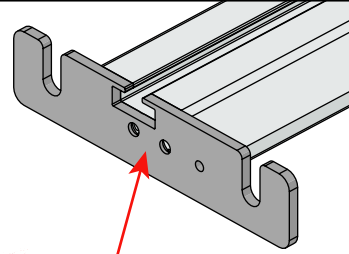
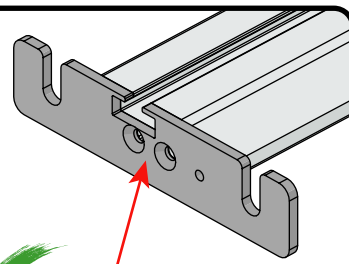

03

01

FX4248

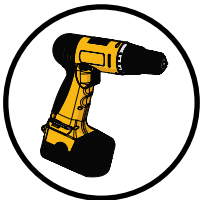

+

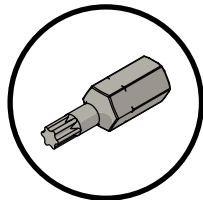

02

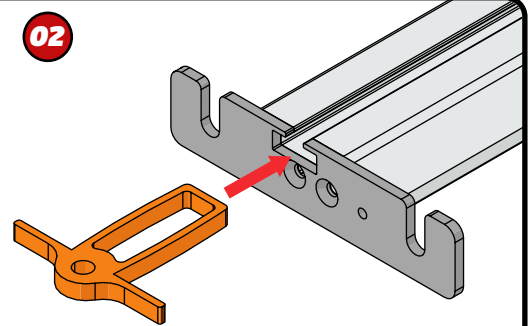

04

1

X4



2

X3

03



11Nm

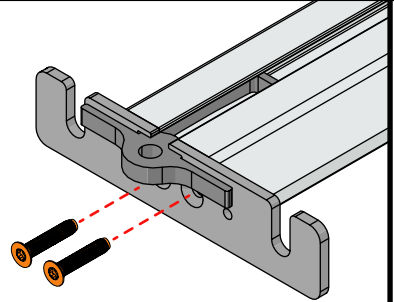

04

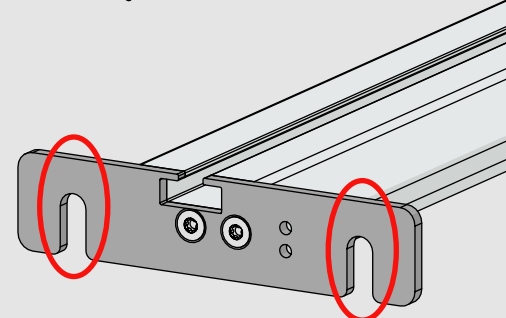
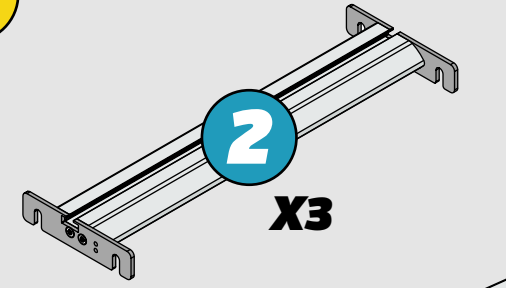
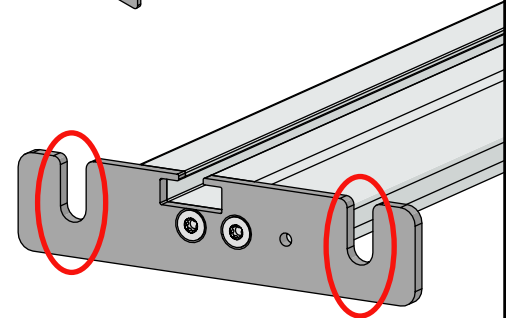
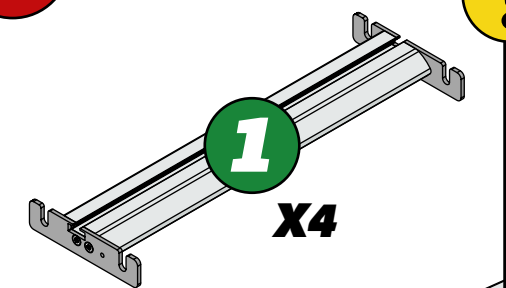
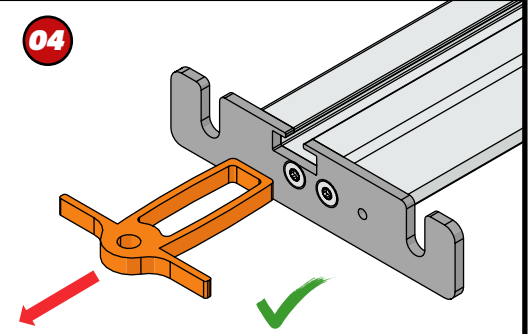

05

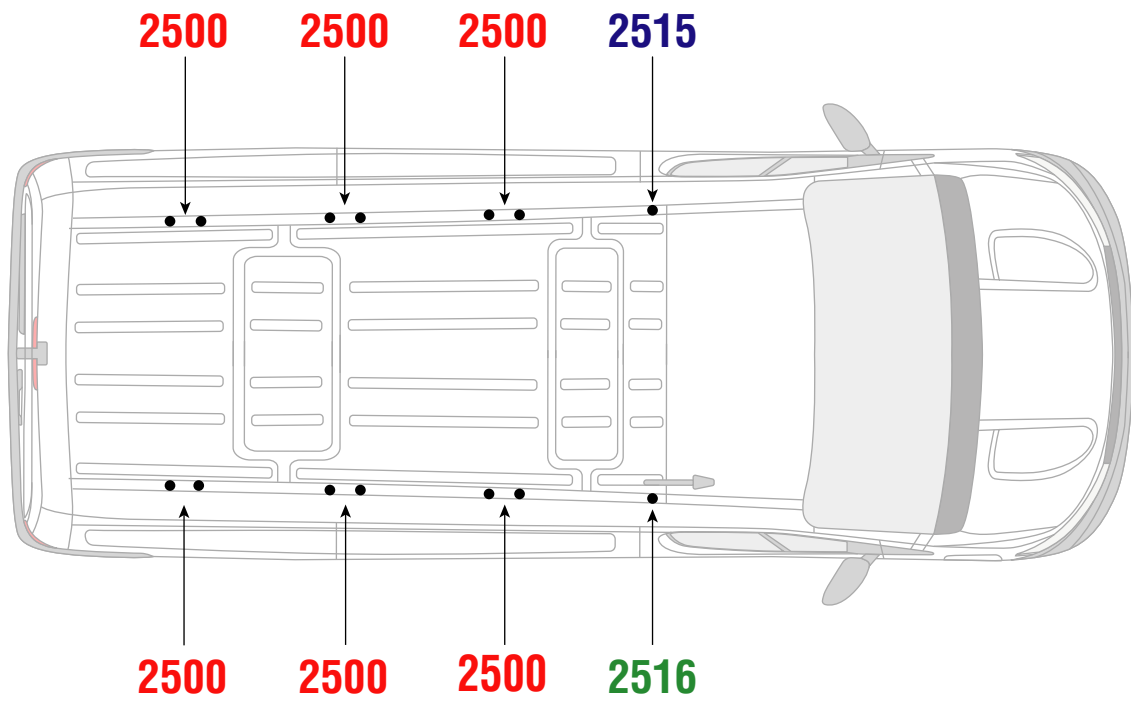

2500

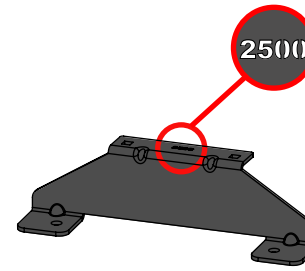

2515

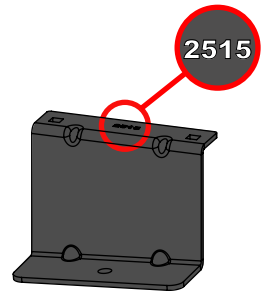

2516

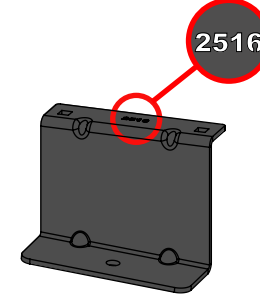

06

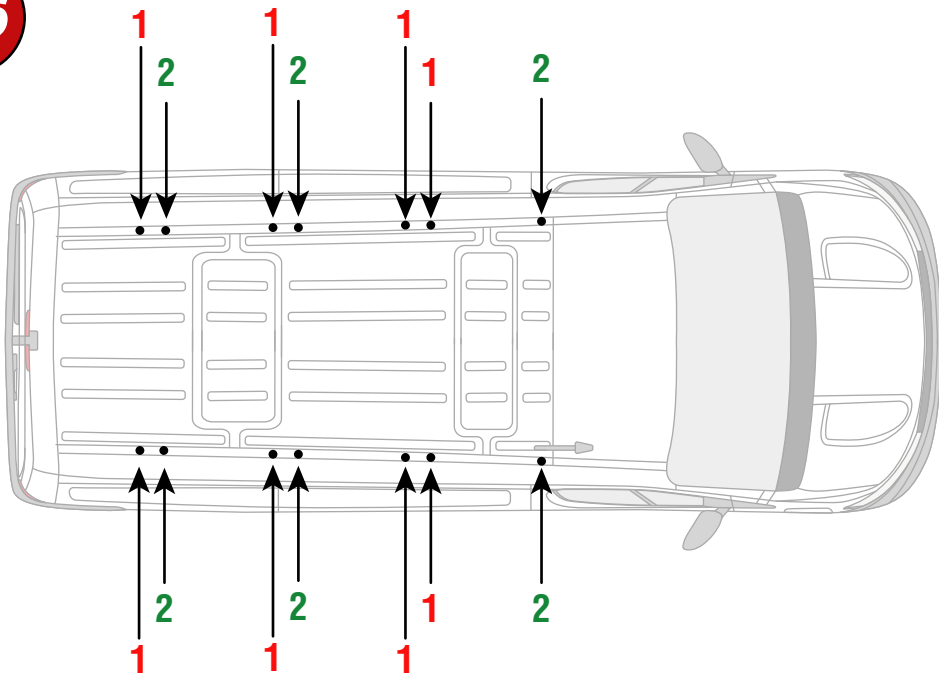

1



07

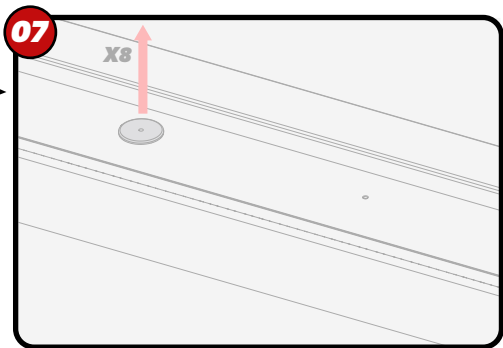

2



08

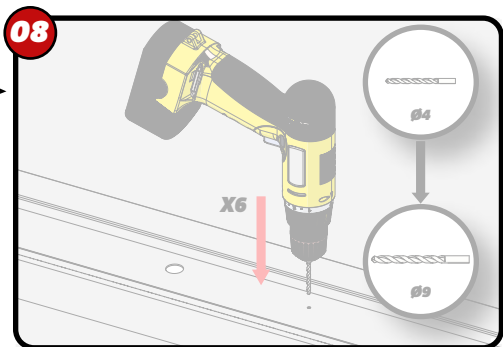

07

X8

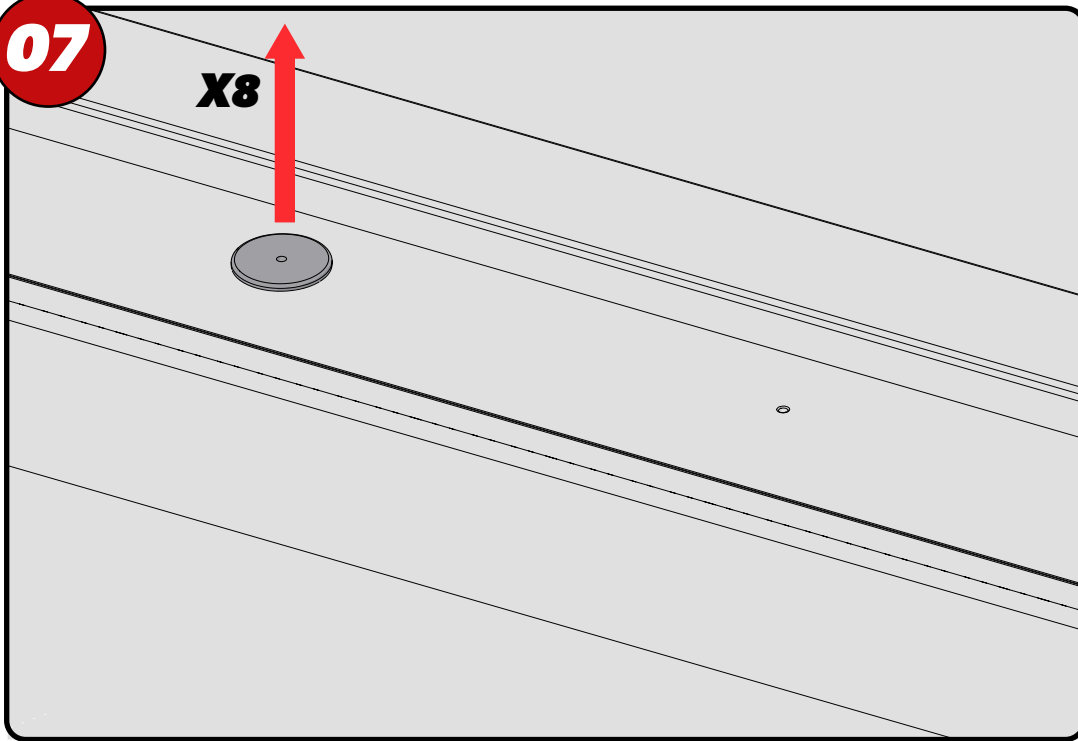

08

X6

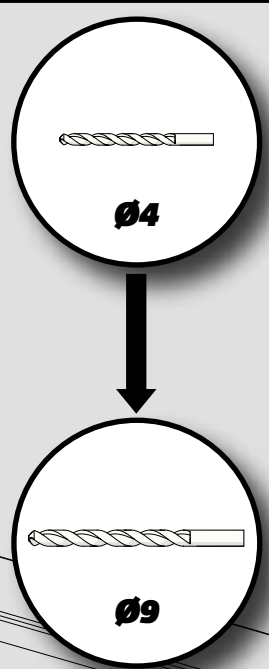
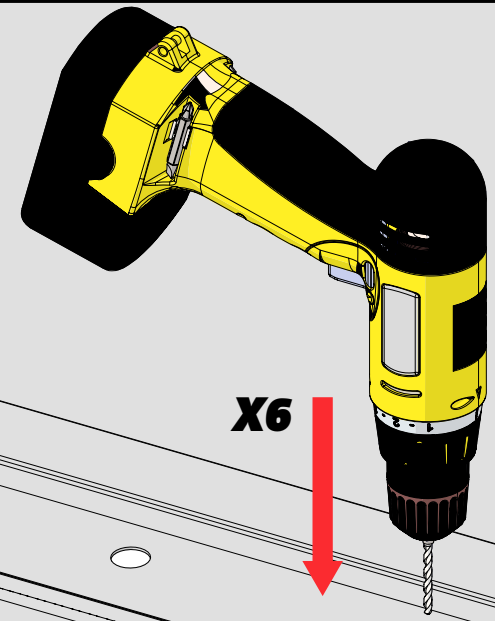

09

FX4011 (M8)

X6

FX4318 (M8)

FX4011 (M8)

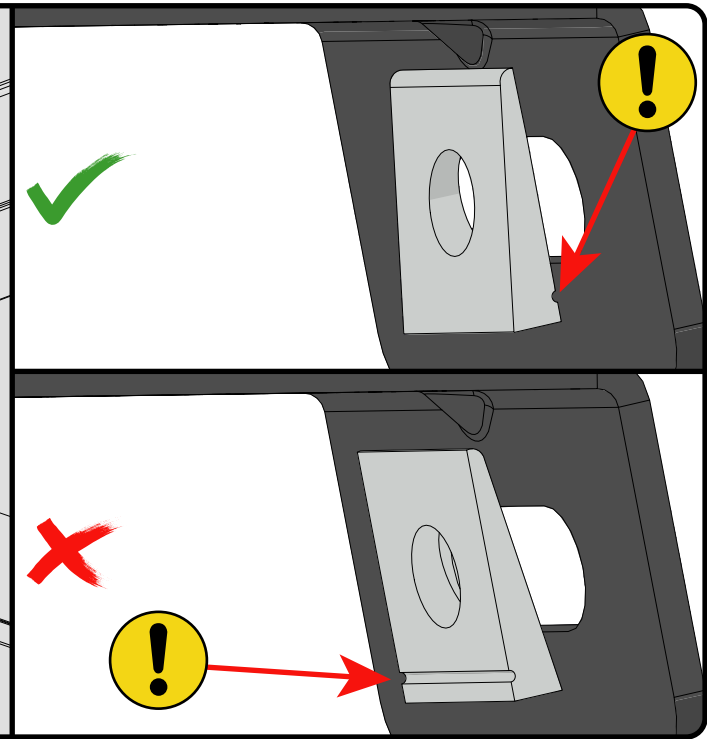
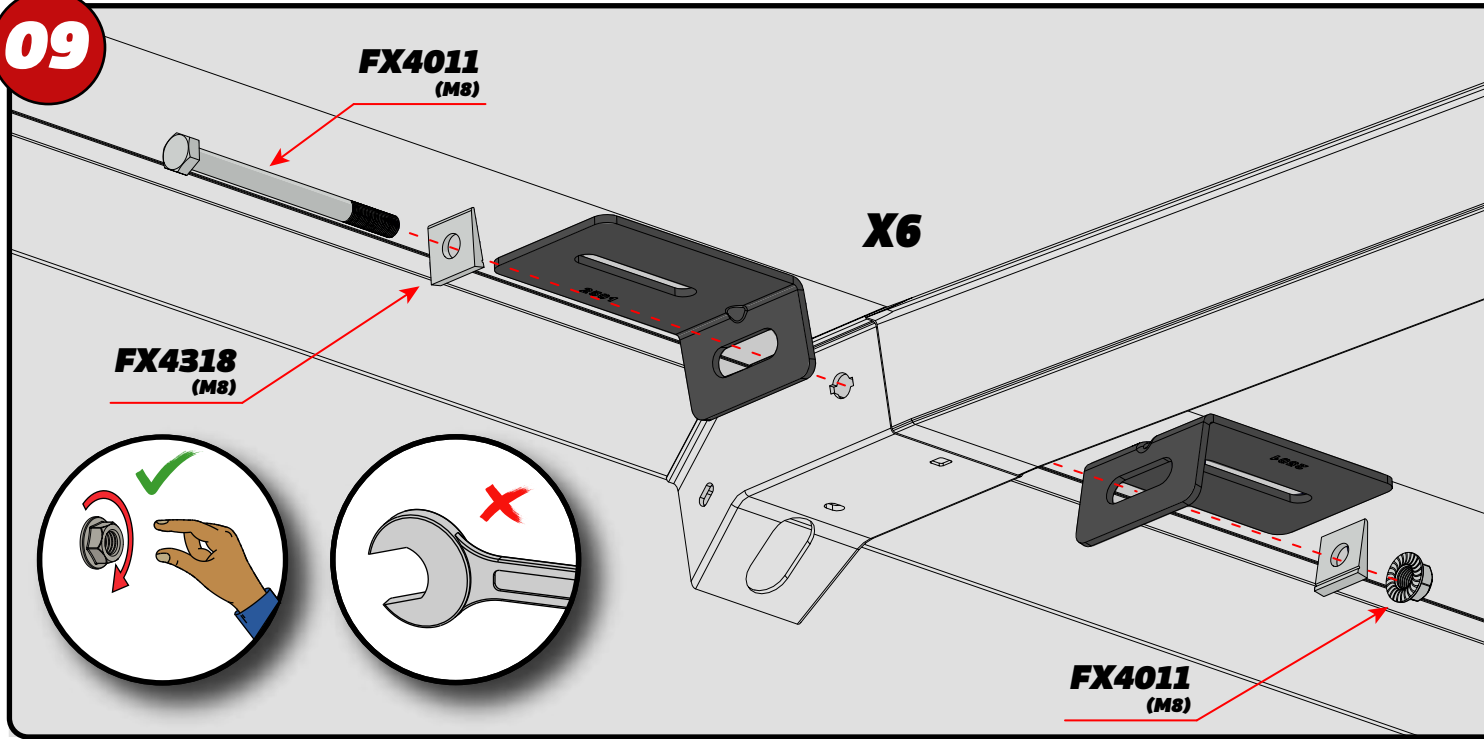
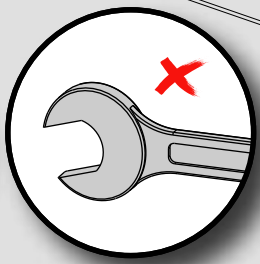
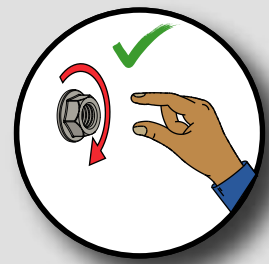

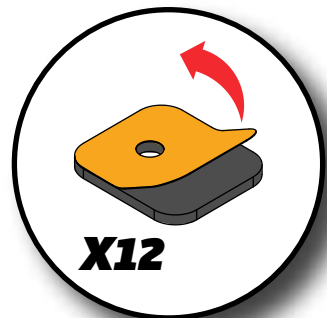
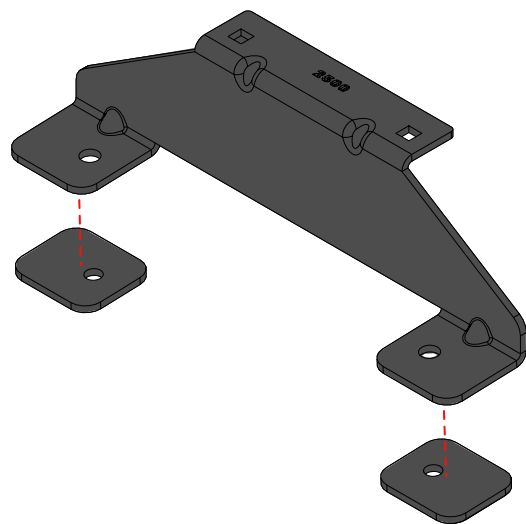
10**X12**

EN - STICK GASKETS TO ALL BRACKETS
 DE - KLEBEN SIE DIE DICHTUNG AN ALLEN HALTERUNGEN
 FR - COUSSINETS ADHÉSIFS À TOUS LES SUPPORTS
 NL - PLAK PAKKING OP ALLE BEUGELS
 ES - PEGA LAS ALMOHADILLAS A TODOS LOS SOPORTES
 IT - ADESIVI GUARNIZIONI A TUTTE LE STAFFE

SV - FÄST GUMMI PÅ ALLA FÄSTEN
 DA - KLÆB GUMMI PÅ ALLE BESLAG
 NO - PLIST GUMMI PÅ ALLE BRAKKETTER
 PL - NAKLEJ USZCZELKI DO WSZYSTKICH WSPORNIKÓW
 CS - PRILEPTE TĚSNĚNÍ NA VŠECHNY DRŽÁKY

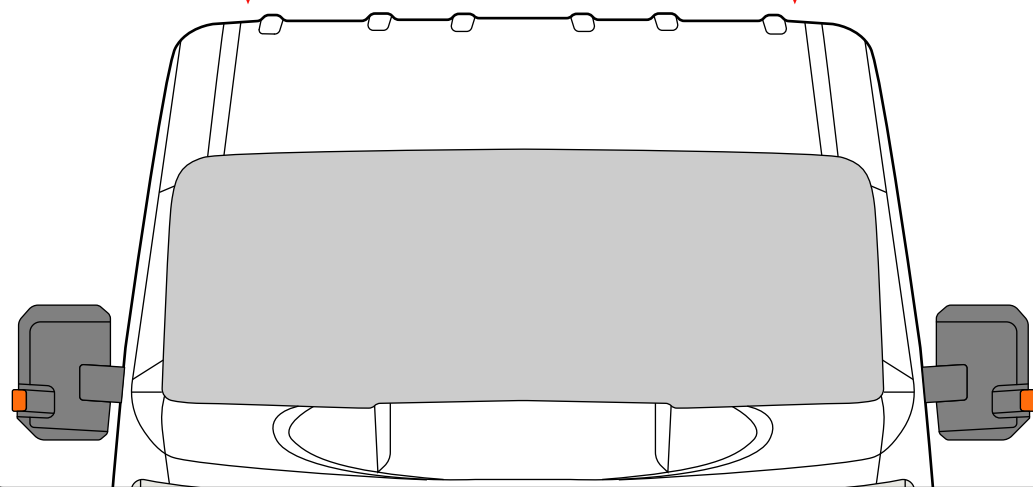
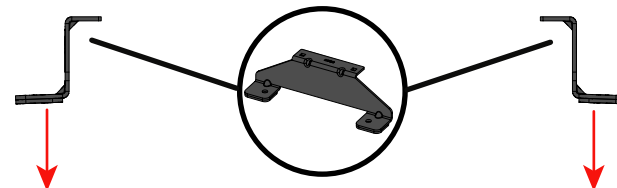
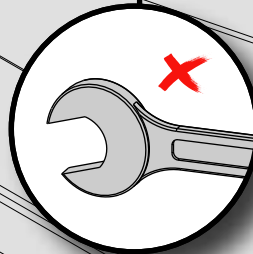
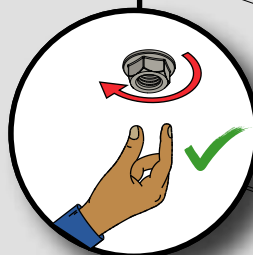
11**12****FX4028**
(M8X25)**X6****FX4011**
(M8)**FX4014****X6****FX4011**
(M8)

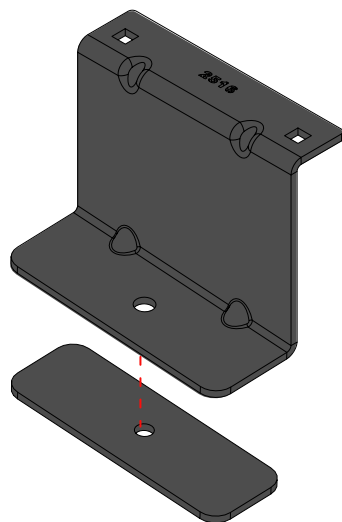
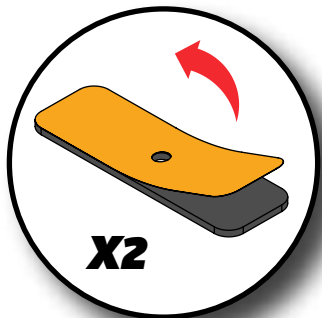
13

EN - STICK GASKETS TO ALL BRACKETS
 DE - KLEBEN SIE DIE DICHTUNG AN ALLEN HALTERUNGEN
 FR - COUSSINETS ADHÉSIFS À TOUS LES SUPPORTS
 NL - PLAK PAKKING OP ALLE BEUGELS
 ES - PEGA LAS ALMOHADILLAS A TODOS LOS SOPORTES
 IT - ADESIVI GUARNIZIONI A TUTTE LE STAFFE

SV - FÄST GUMMI PÅ ALLA FÄSTEN
 DA - KLÆB GUMMI PÅ ALLE BESLAG
 NO - PLIST GUMMI PÅ ALLE BRAKKETTER
 PL - NAKLEJ USZCZELKI DO WSZYSTKICH WSPORNIKÓW
 CS - PŘILEPTE TĚSNĚNÍ NA VŠECHNY DRŽÁKY

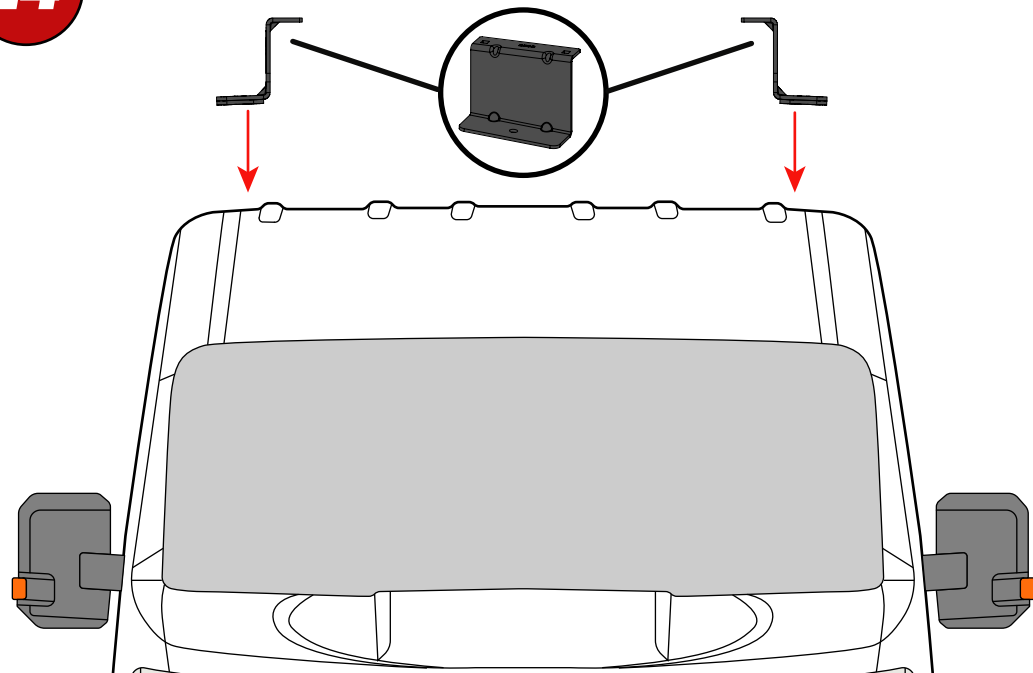
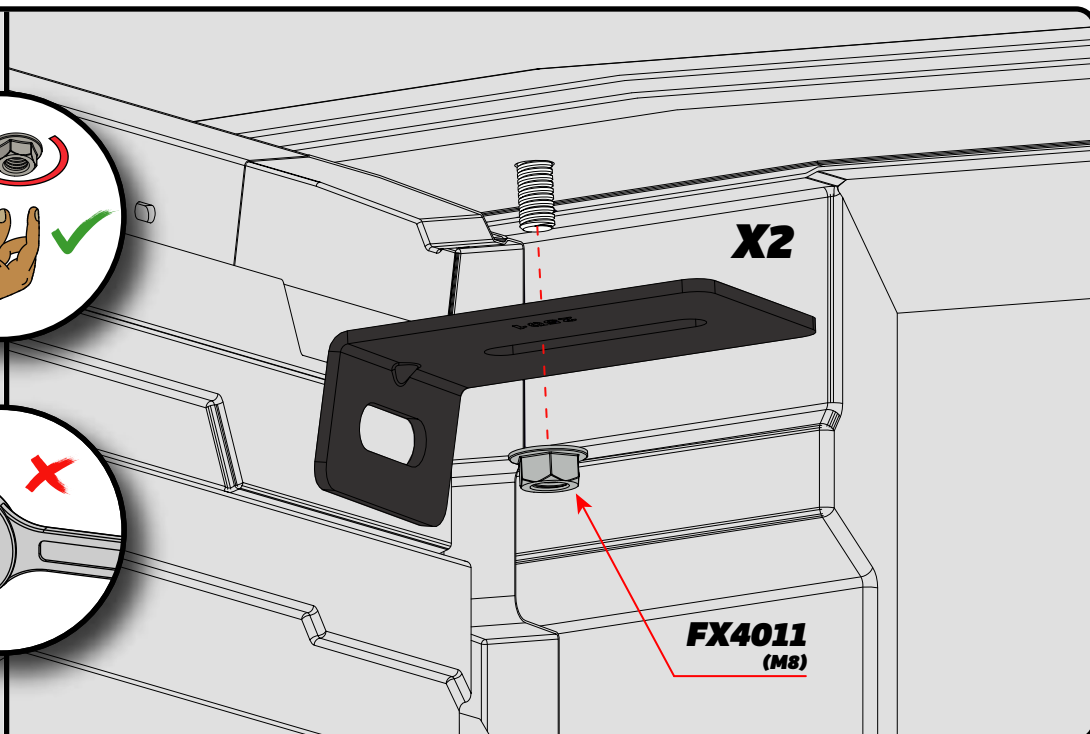
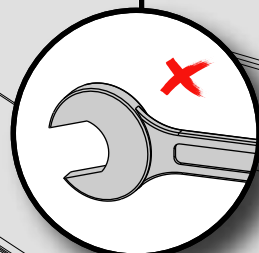
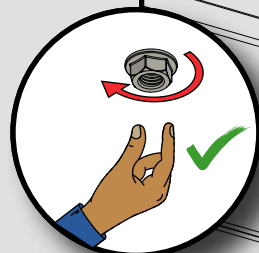
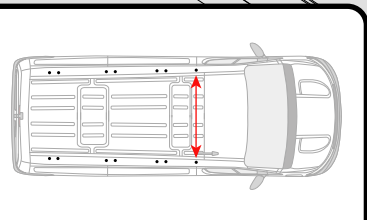
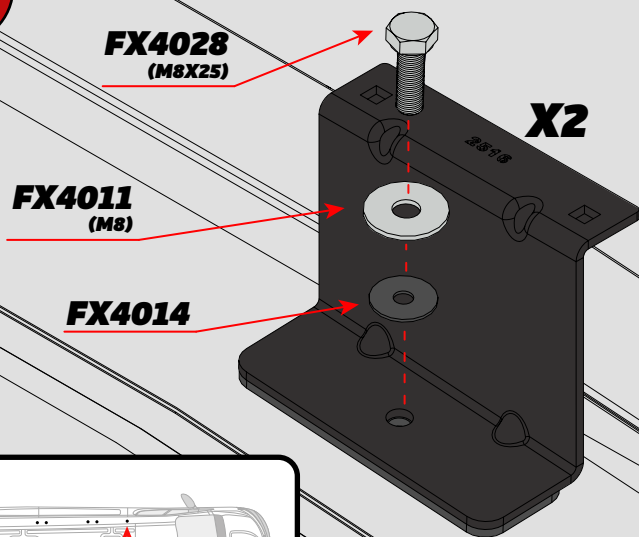
14**15**

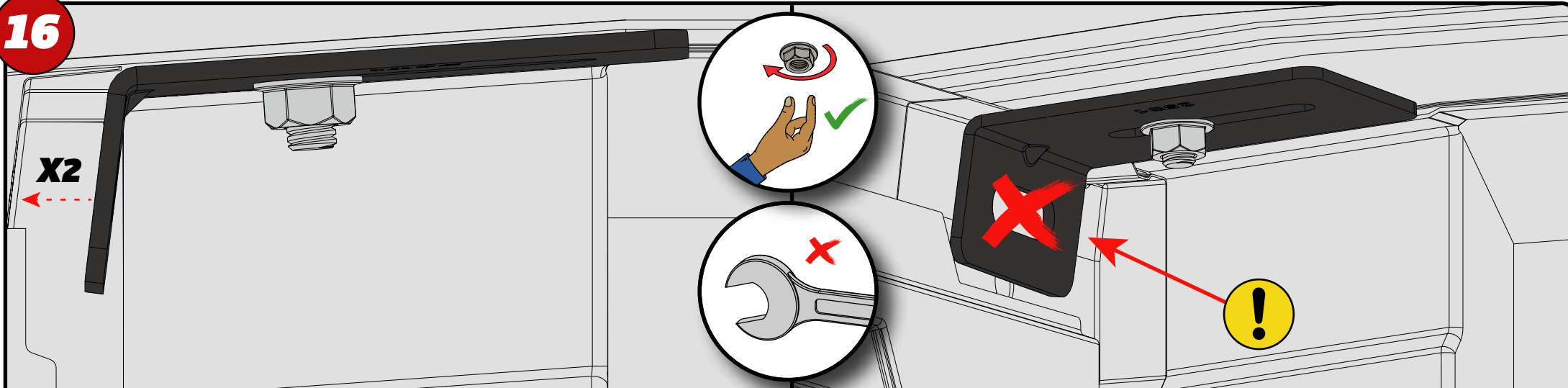
16

EN - SLIDE BRACKET BACK TO THE VAN LINING. NO ADDITIONAL FIXINGS NEEDED

DE - SCHIEBEN SIE DIE HALTERUNG ZURÜCK ZUR VERKLEIDUNG DES LIEFERWAGENS. KEINE ZUSÄTZLICHEN BEFESTIGUNGEN ERFORDERLICH.

FR - FAITES GLISSER LE SUPPORT VERS LE REVÊTEMENT DU FOURGON. AUCUNE AUTRE FIXATION NÉCESSAIRE.

NL - SCHUIF DE BEUGEL TERUG NAAR DE BEKLEDING VAN DE BESTELWAGEN. GEEN EXTRA BEVESTIGINGEN NODIG.

ES - DESLICE EL SOPORTE DE VUELTA AL REVESTIMIENTO DE LA FURGONETA. NO SE NECESITAN FIJACIONES ADICIONALES.

IT - FAR SCORRERE LA STAFFA INDIETRO FINO AL RIVESTIMENTO DEL FURGONE. NESSUN FISSAGGIO AGGIUNTIVO NECESSARIO.

SV - SKJUT TILLBAKA FÄSTET MOT SKÅPBILENS BEKLÄDNAD. INGA YTTERLIGARE FÄSTEN BEHÖVS.

DA - SKUB BESLAGET TILBAGE TIL VAREVOGNENS BEKLÆDNING. INGEN YDERLIGERE FASTGØRELSE NØDVENDIG.

NO - SKYV BRACKETTEN TILBAKE TIL VAREBILENS KLEDNING. INGEN EKSTRA FESTER NØDVENDIG.

PL - PRZESUŃ WSPORNIK Z POWROTEM DO WYSIÓŁKI VANA. NIE SĄ POTRZEBNE DODATKOWE MOCOWANIA.

CS - POSUŇTE DRŽÁK ZPĚT K OBLOŽENÍ DODÁVKY. ŽÁDNÉ DALŠÍ UPEVNĚNÍ NENÍ NUTNÉ.

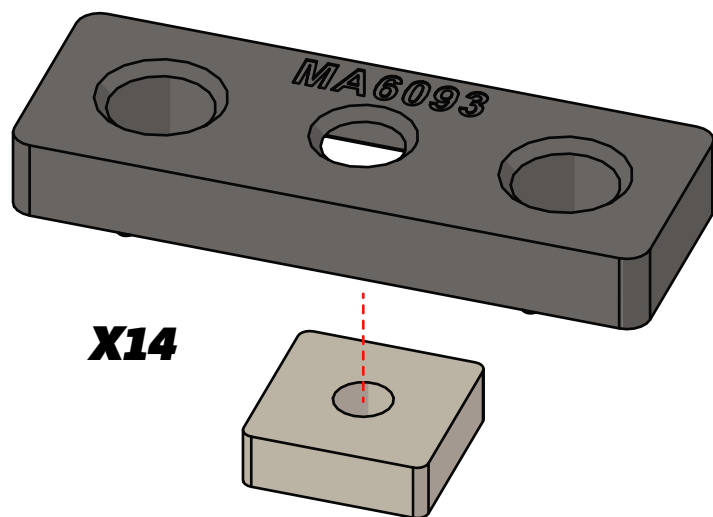
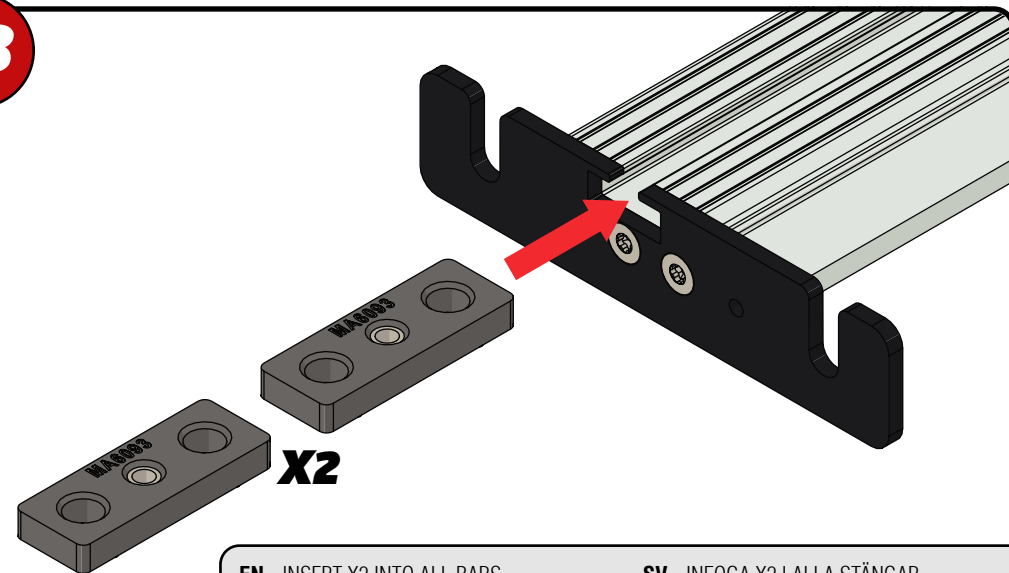
17**X14****18****X2**

EN - INSERT X2 INTO ALL BARS

DE - X2 IN ALLE STANGEN EINFÜGEN

FR - INSÉRER X2 DANS TOUTES LES BARRES

NL - PLAATS X2 IN ALLE BARS

ES - INSERTAR X2 EN TODAS LAS BARRAS

IT - INSERIRE X2 IN TUTTE LE BARRE

SV - INFOGA X2 I ALLA STÅNGAR

DA - INDSÆT X2 I ALLE STÆNGER

NO - SETTE X2 I ALLE STÆNGENE

PL - WSTAW X2 DO WSZYSTKICH PRĘTÓW

CS - VLOŽTE X2 DO VŠECH TYČÍ

19

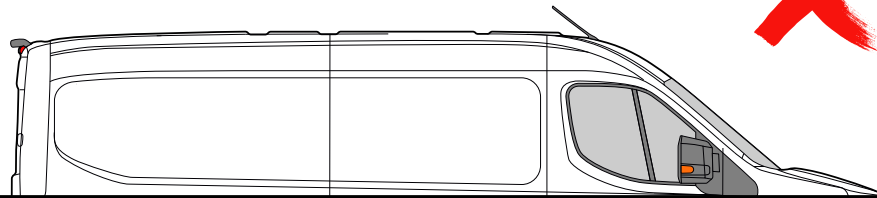
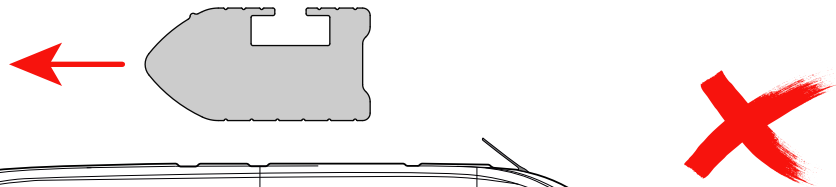
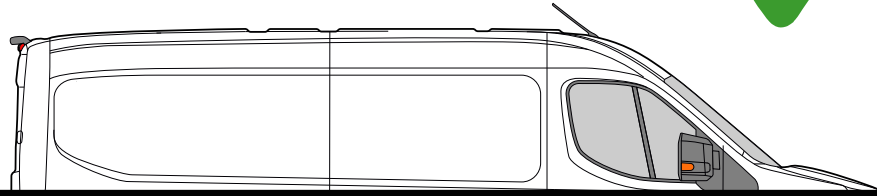
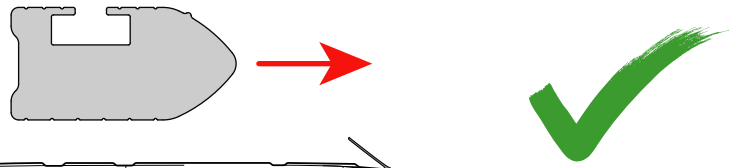

20

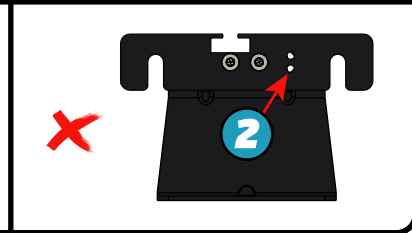
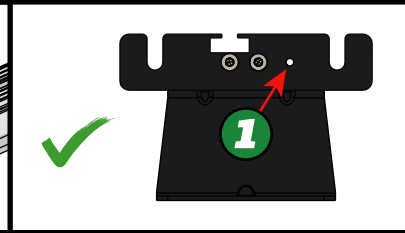
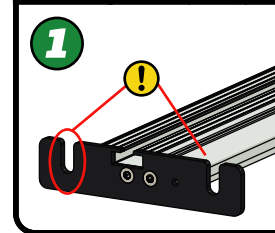
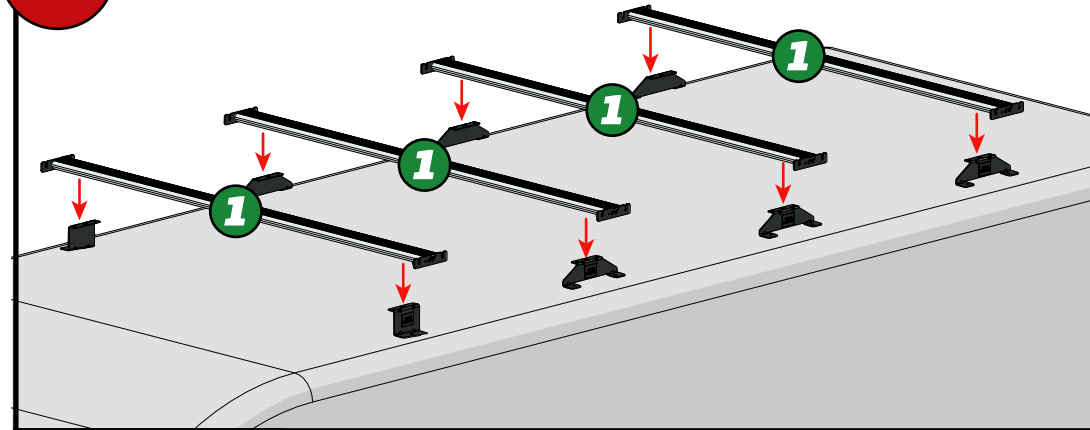

21

FX4016 (M6)

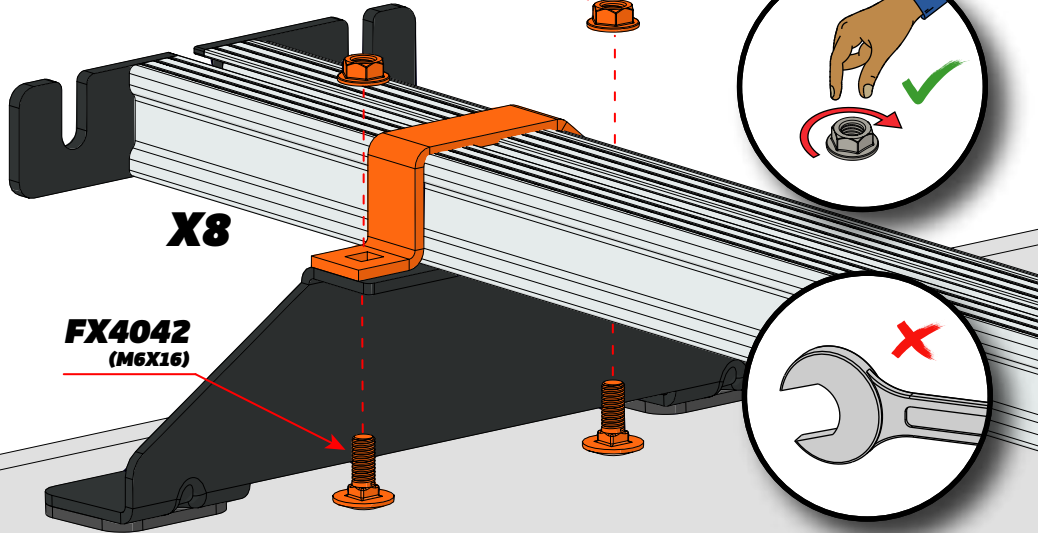

22

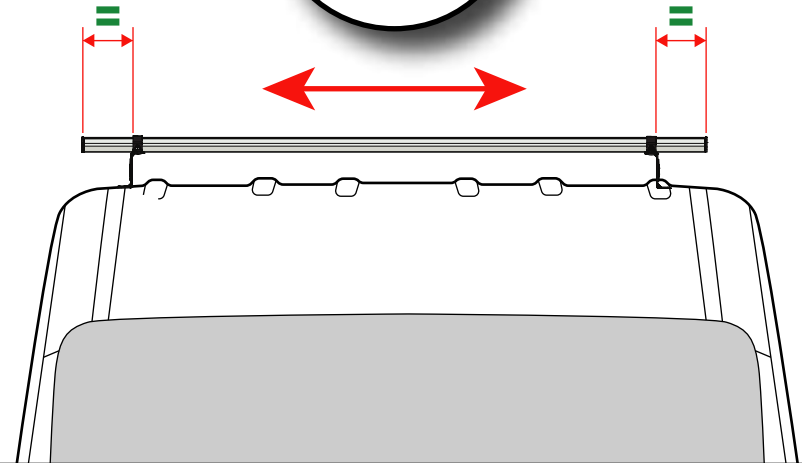
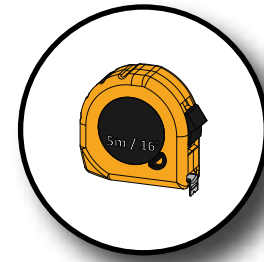

23

FX4001

15Nm

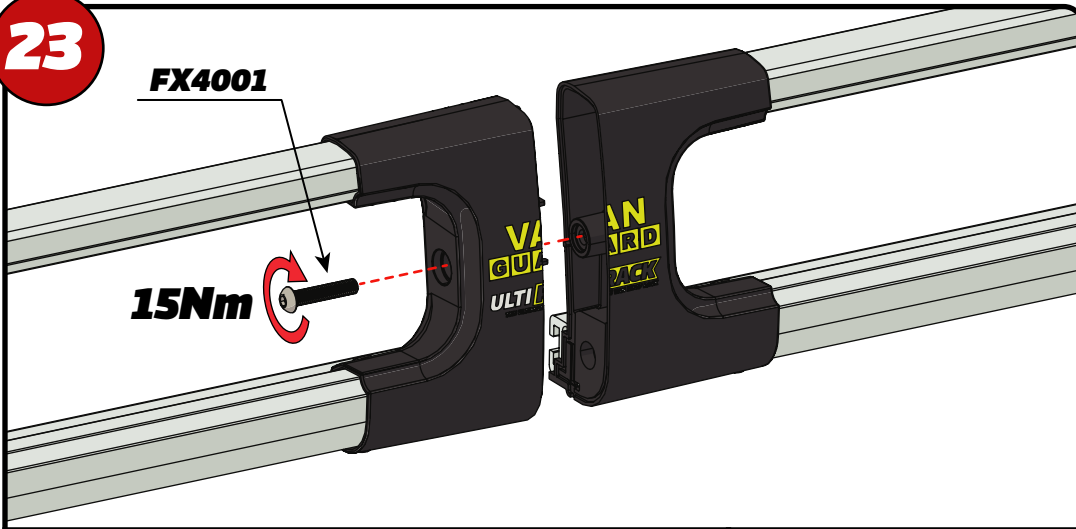

X2

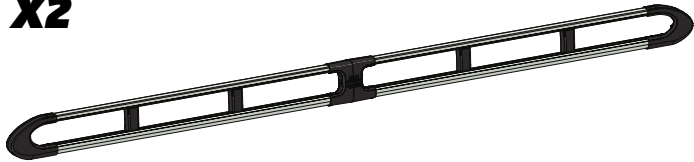

FX4008



24

X14

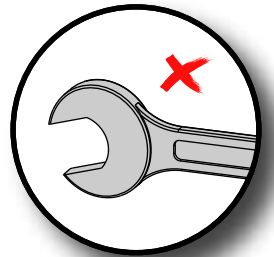
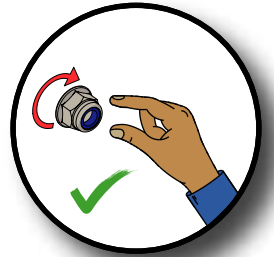
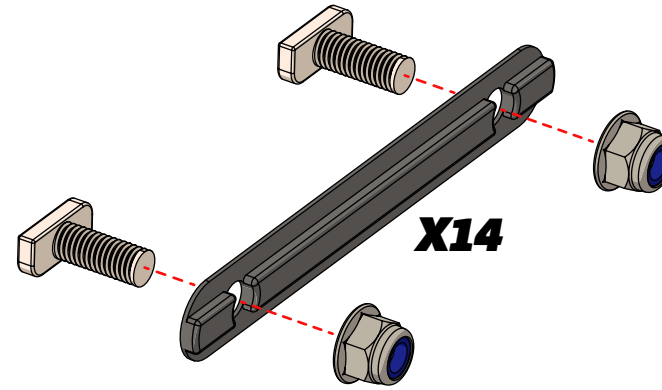

25

X7

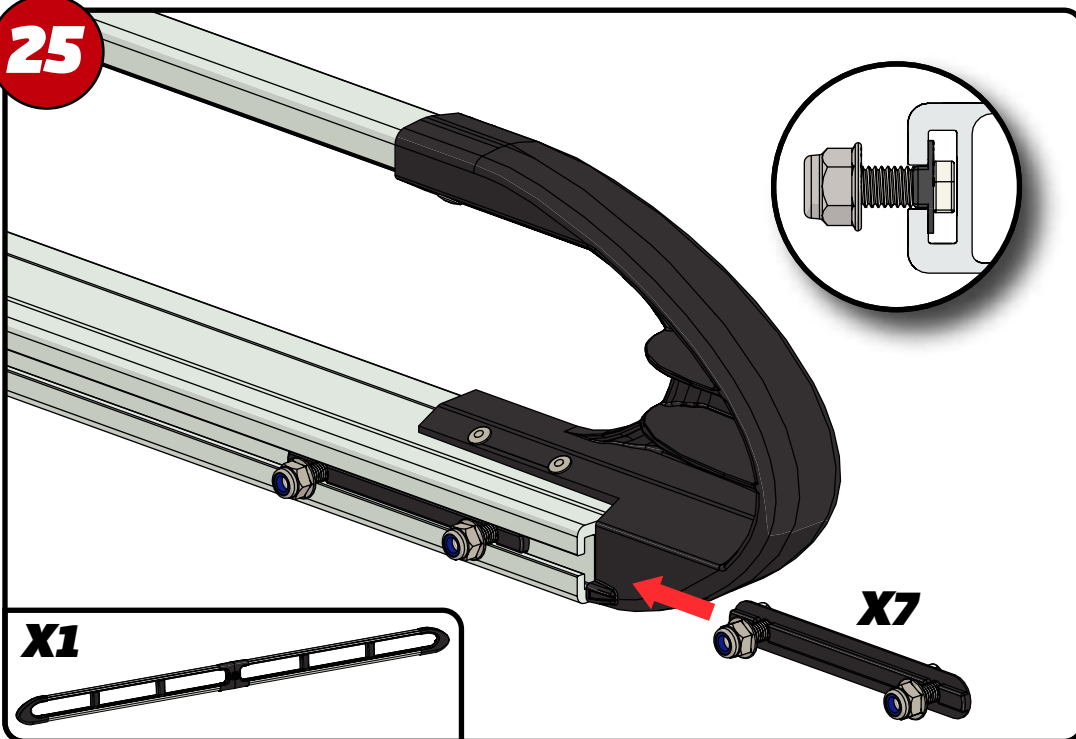

X1

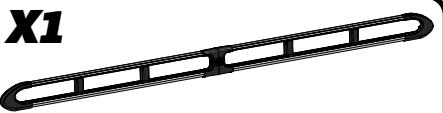

26

X7

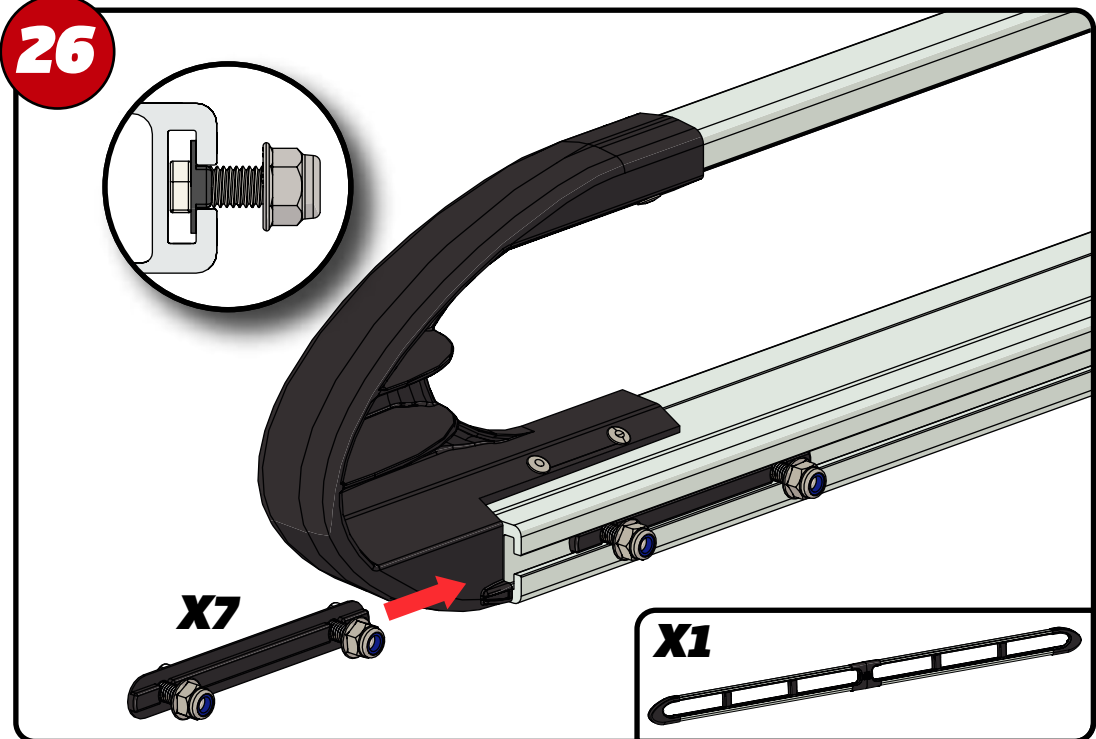

X1

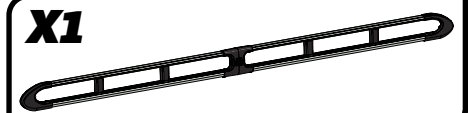

27

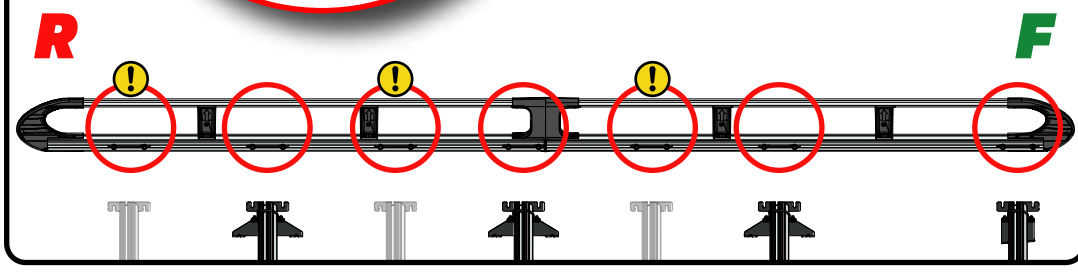
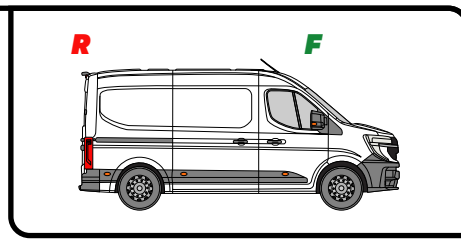
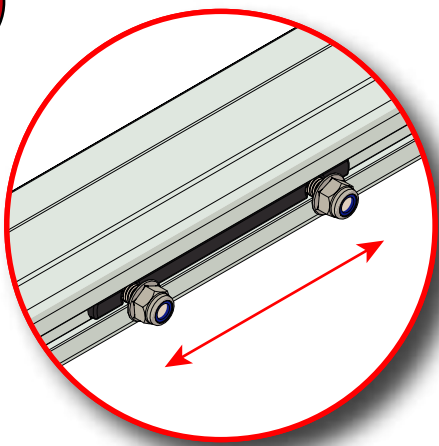

28

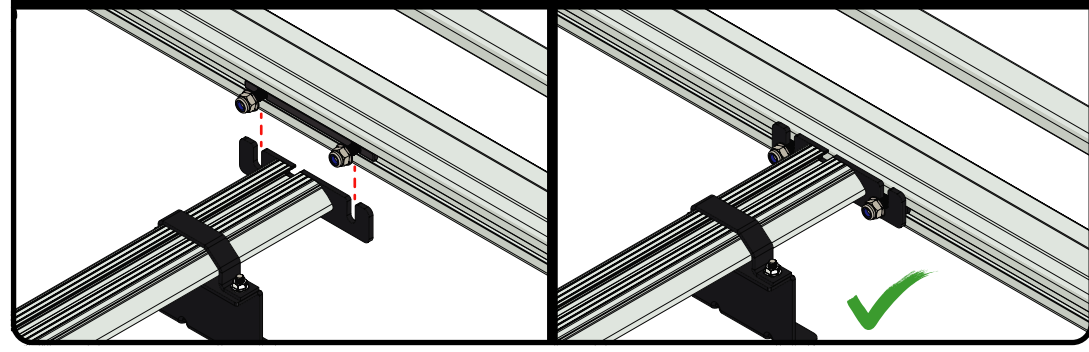
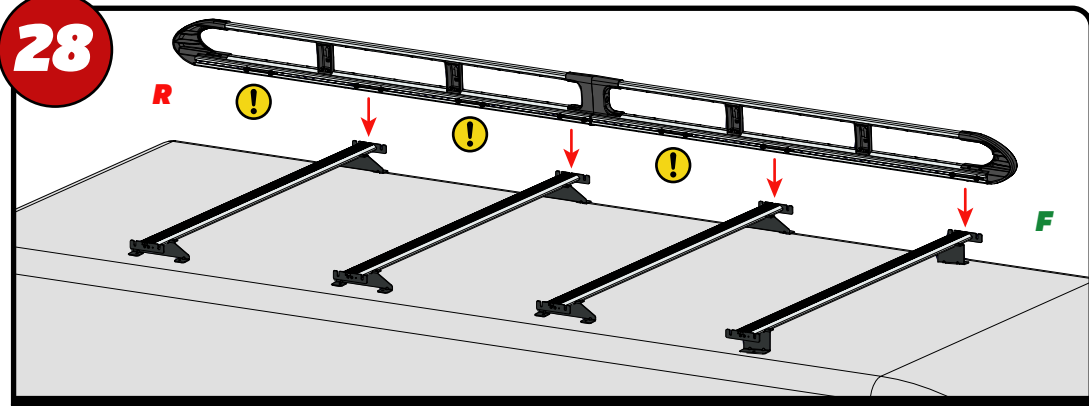

29

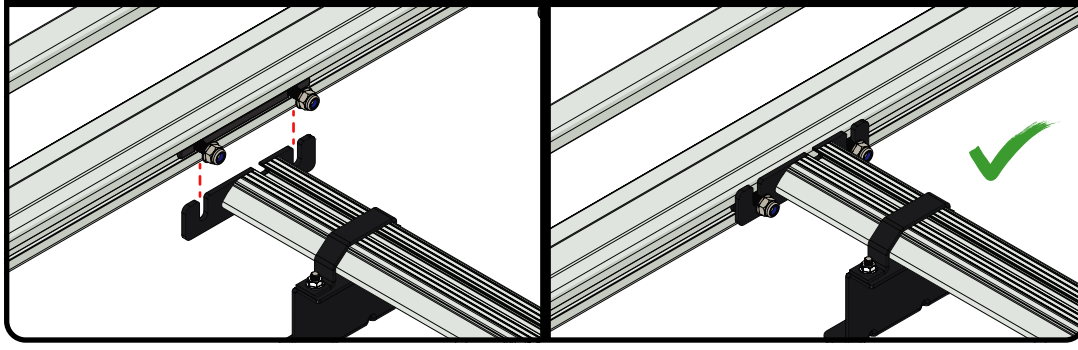
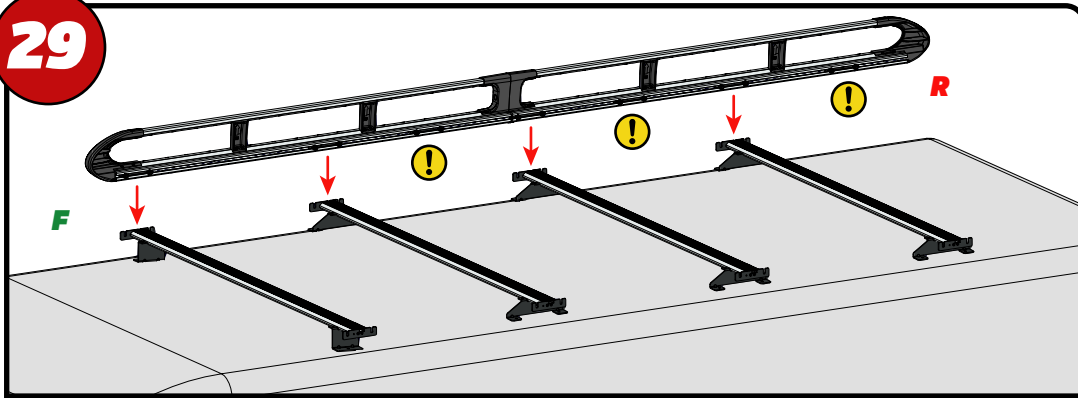

30

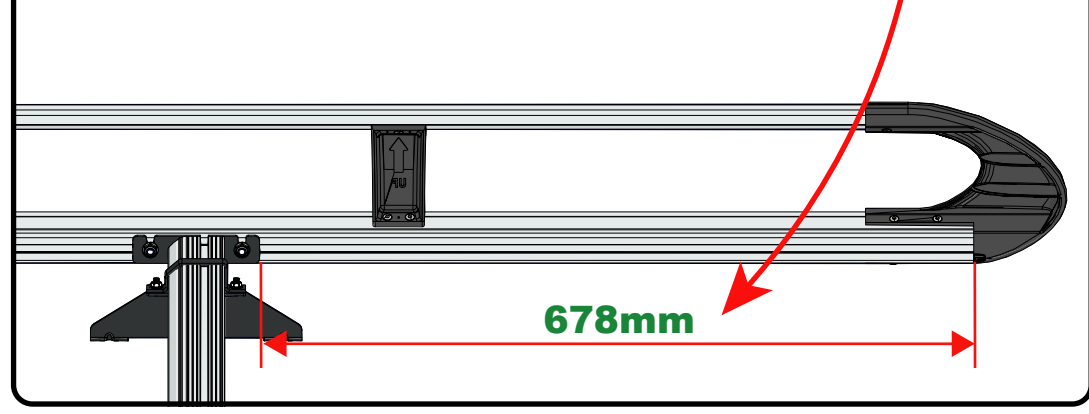
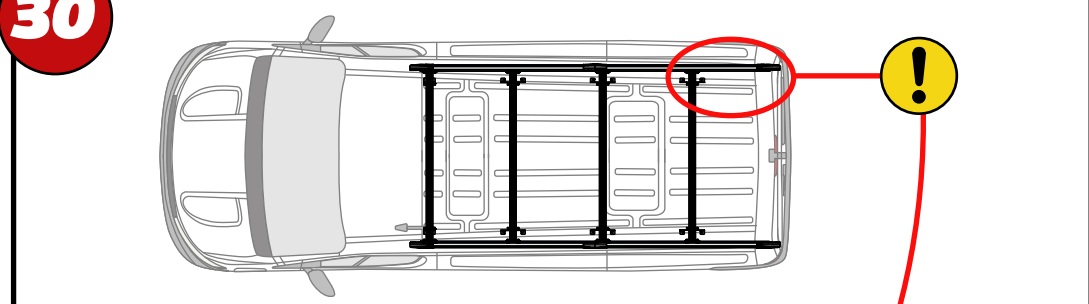

31

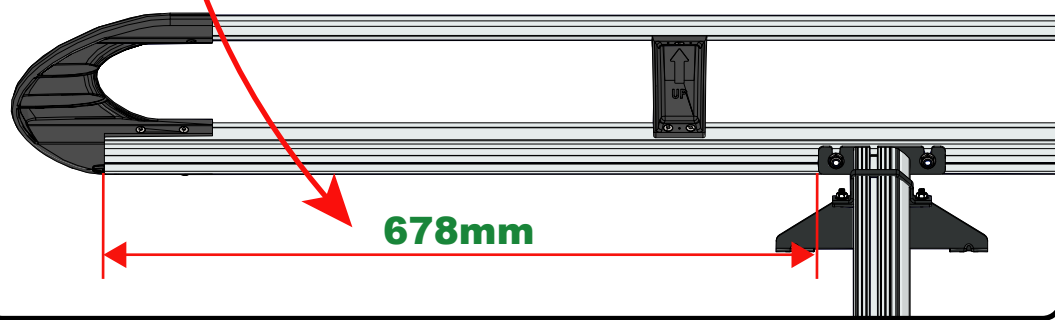
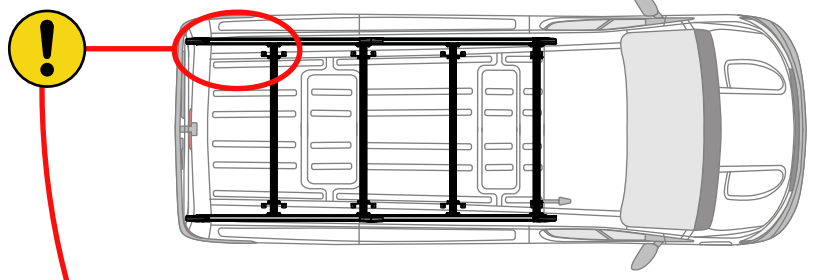

32

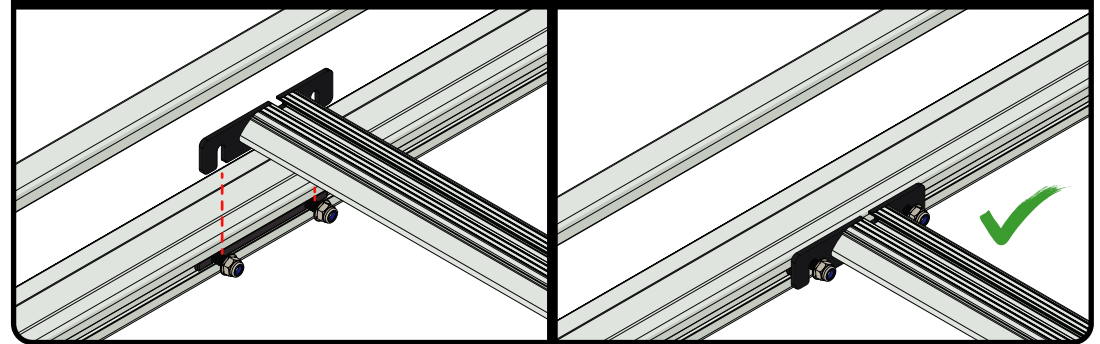
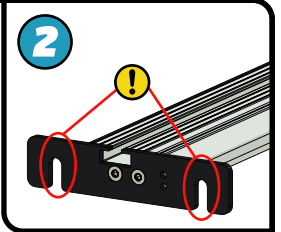
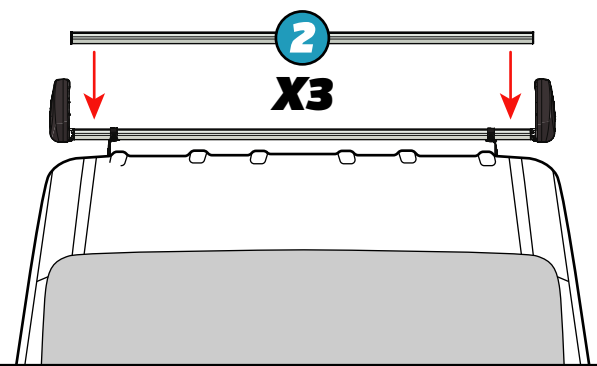

33

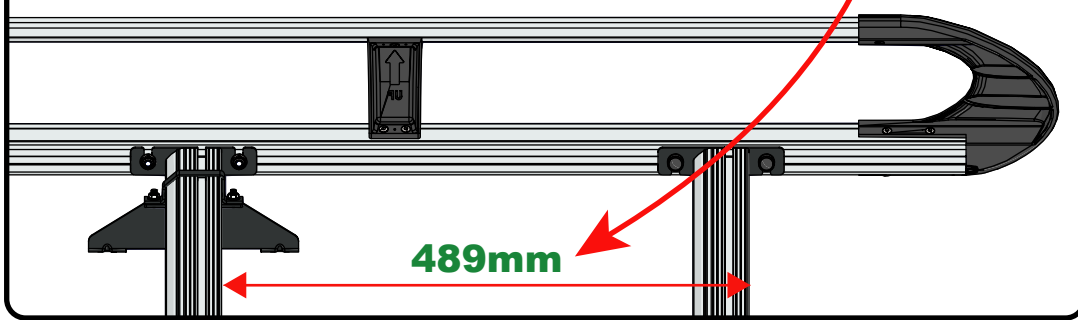
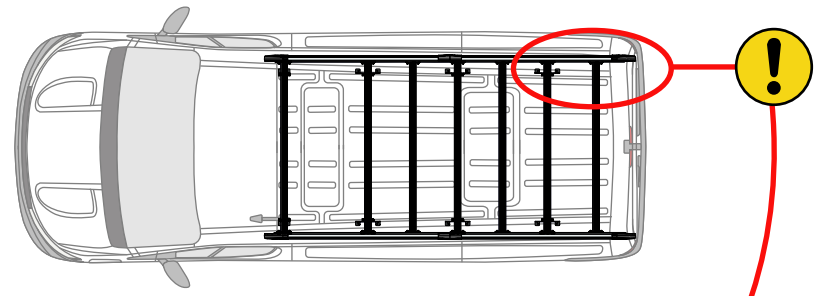

34

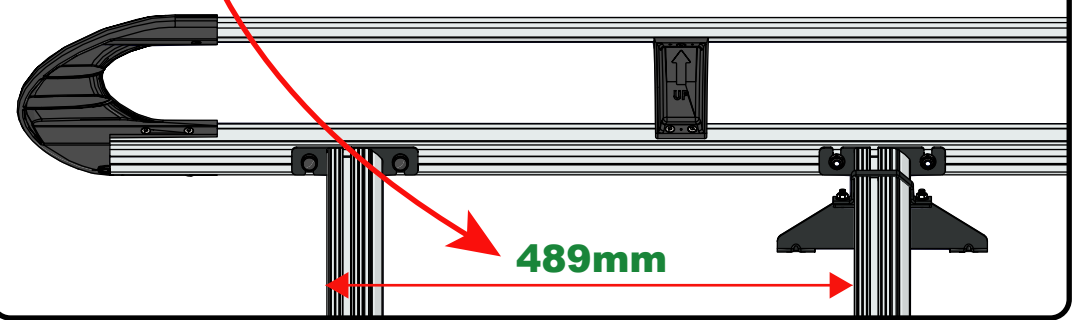
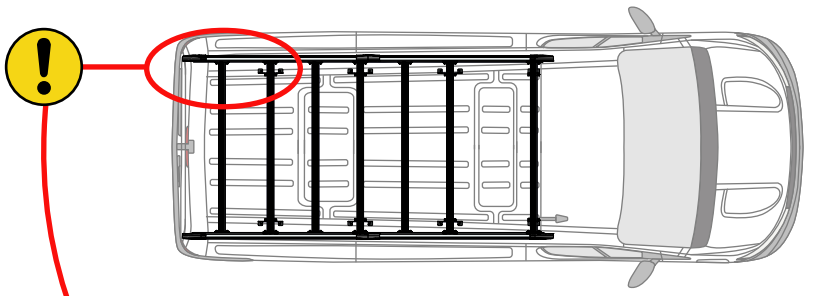

35

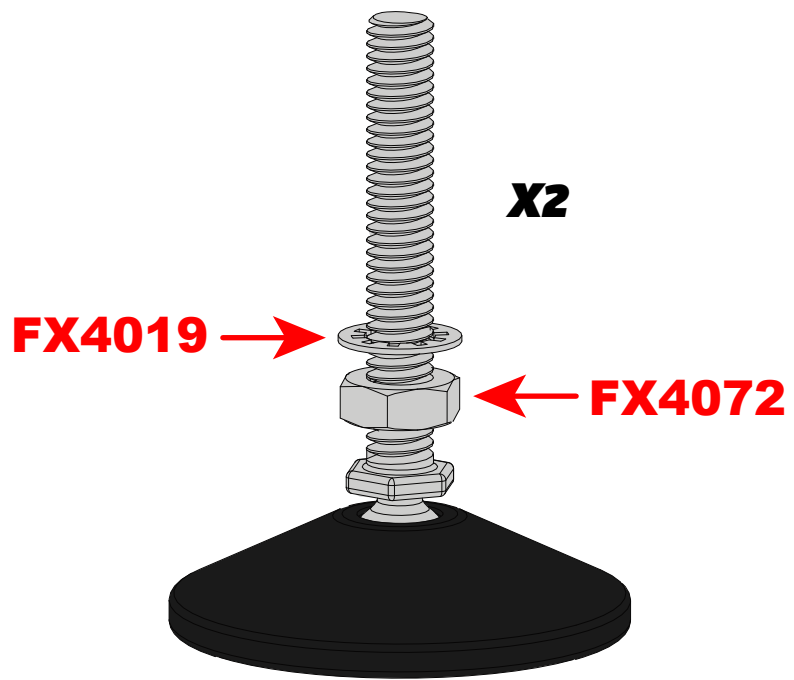

36

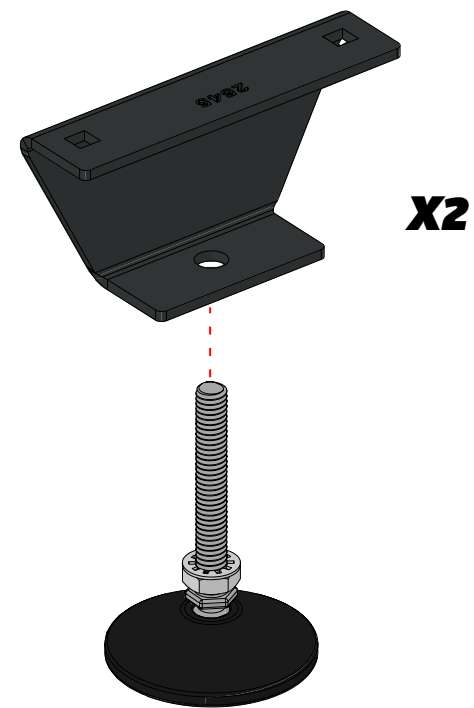

37

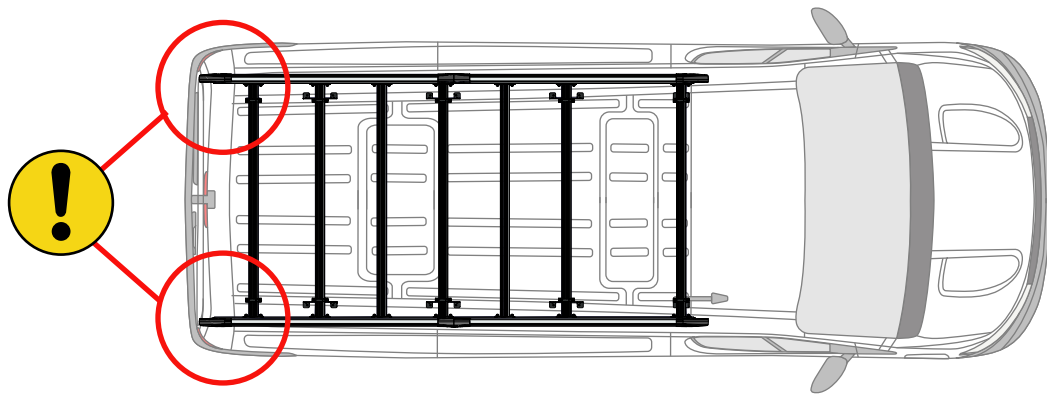

38

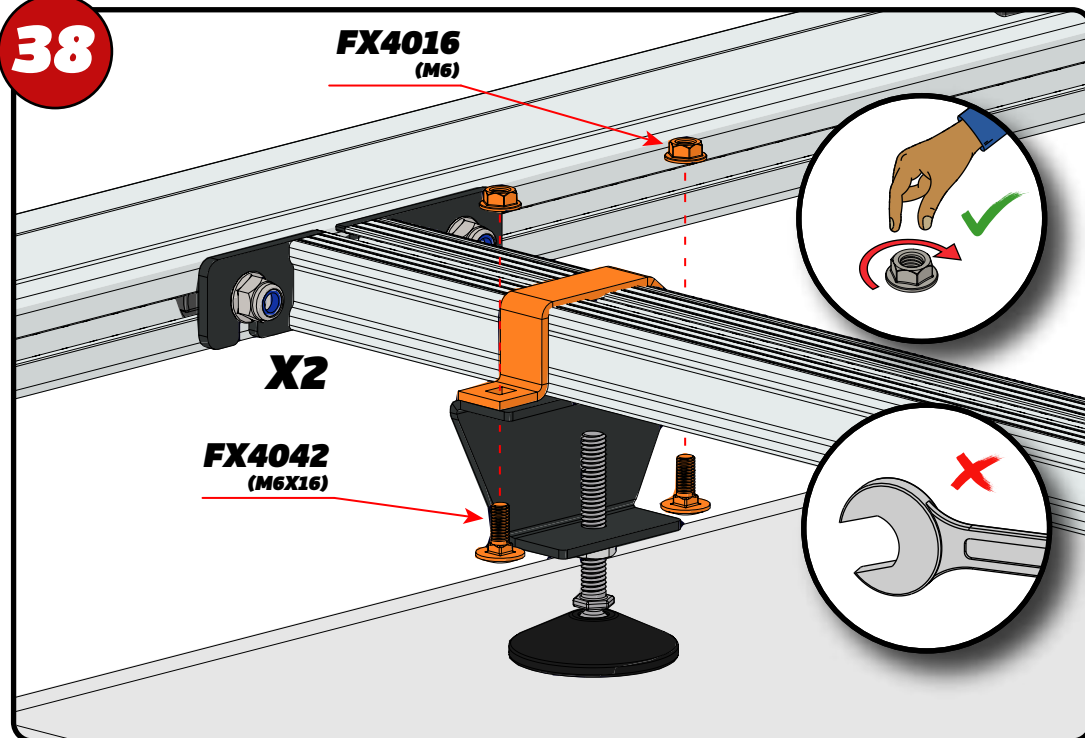

39

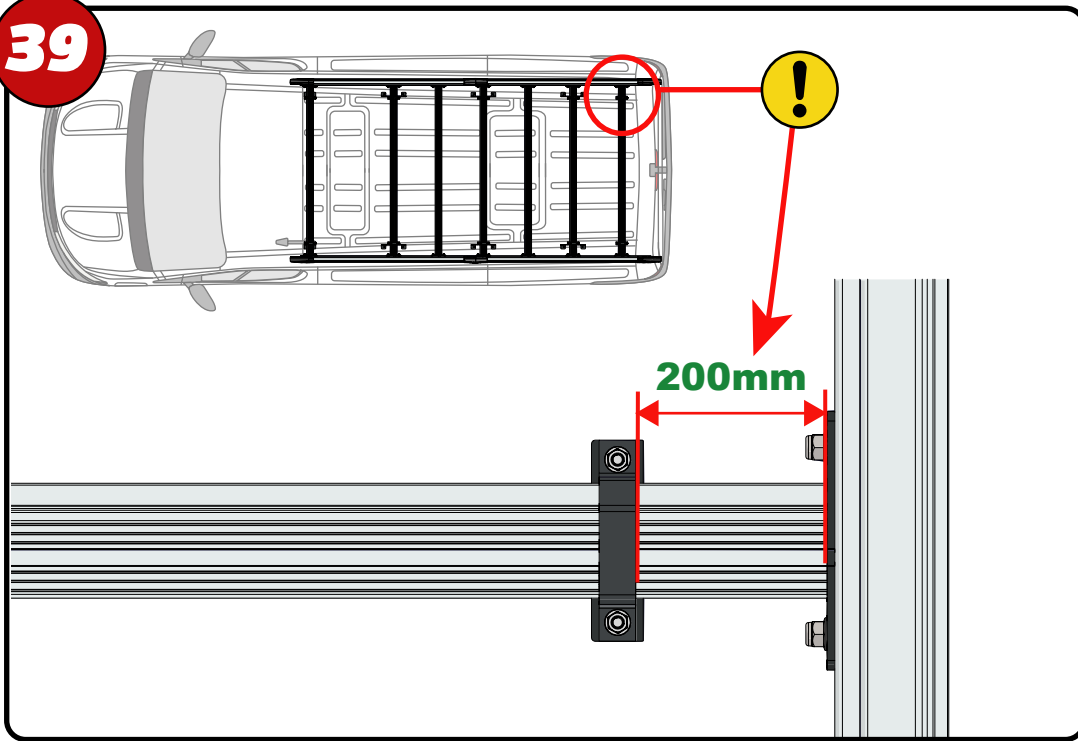

40

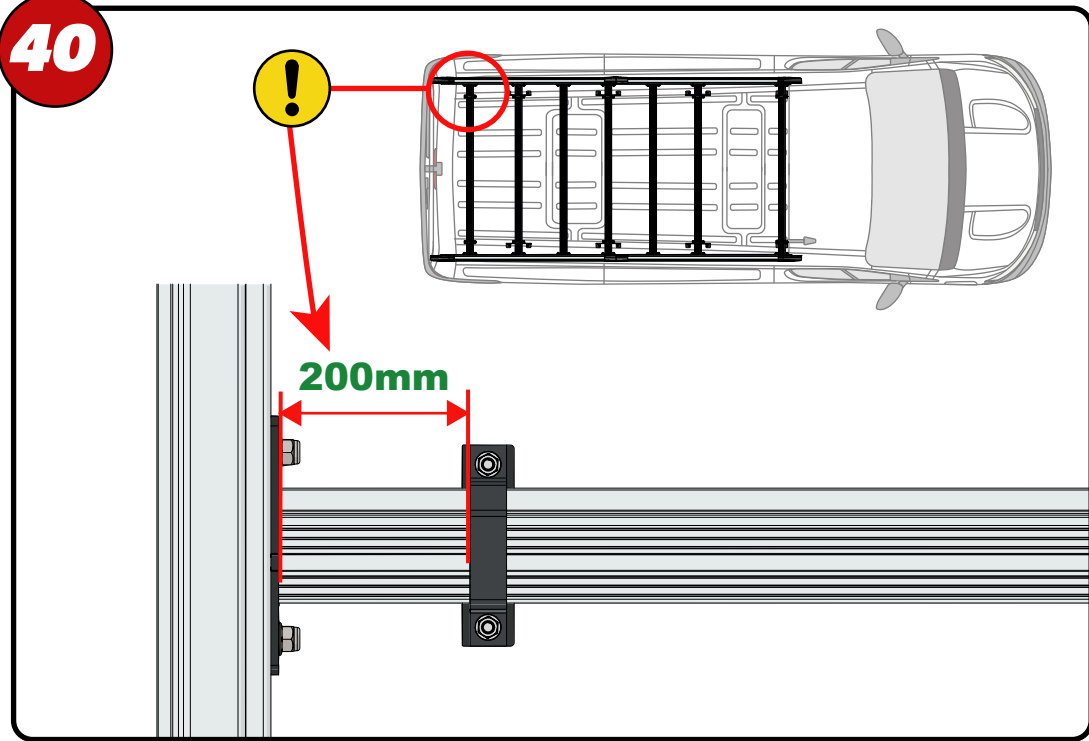

41

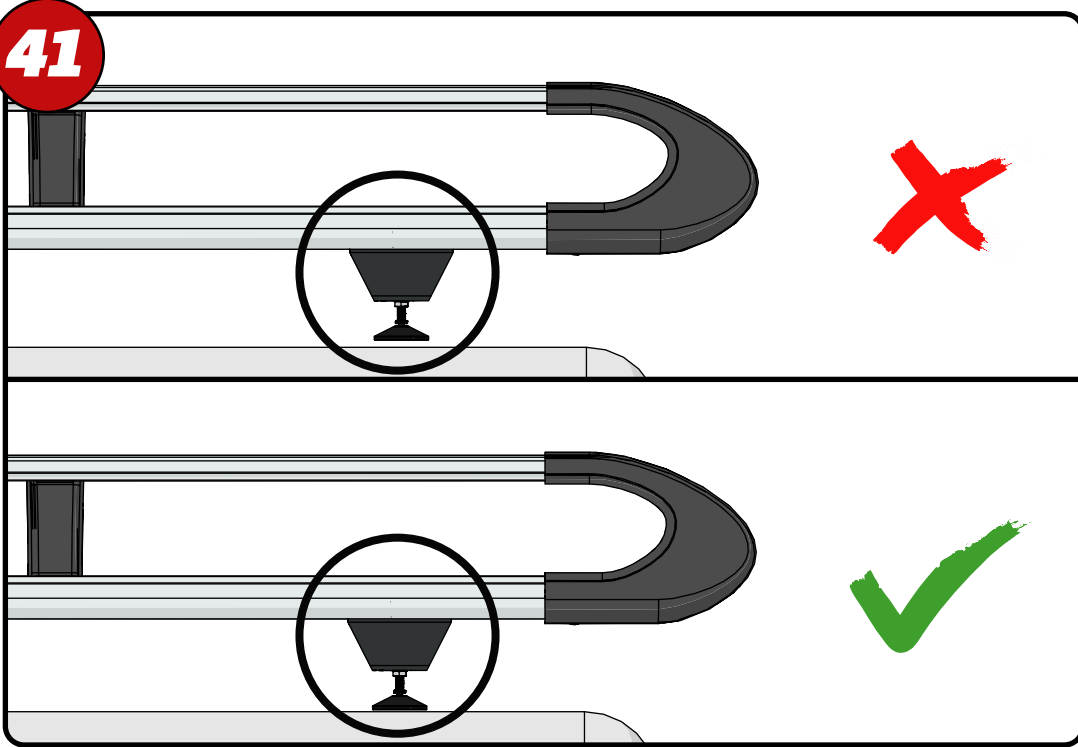

42

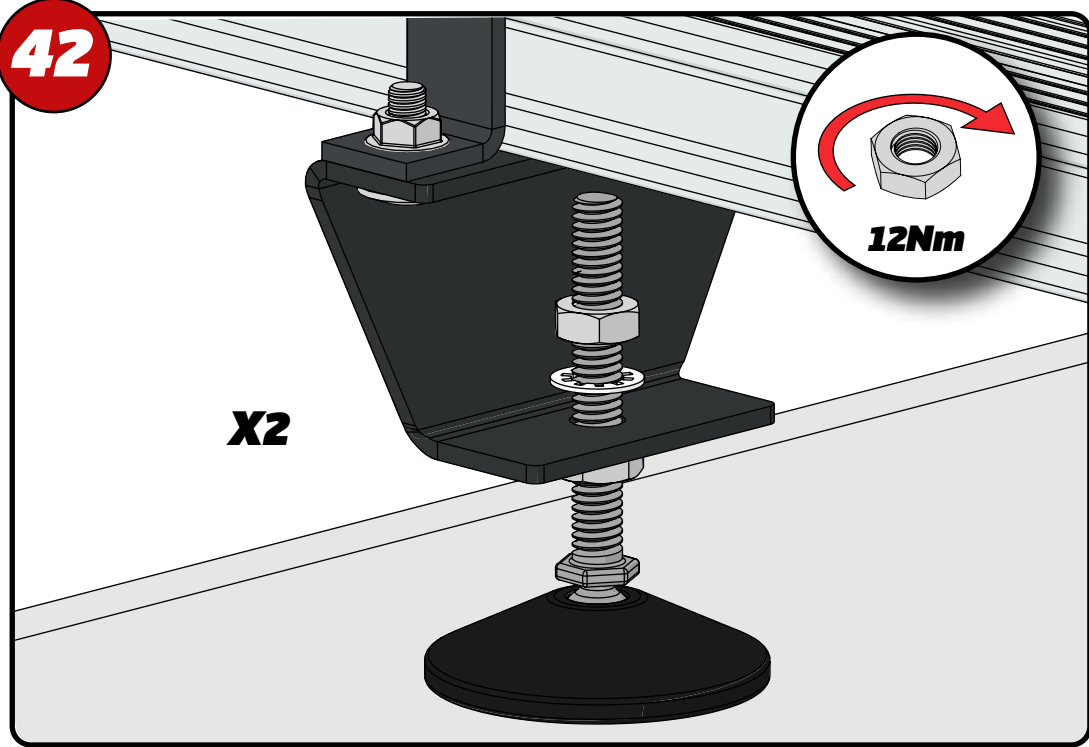

43

XXX =
PAGE 2 OF 20

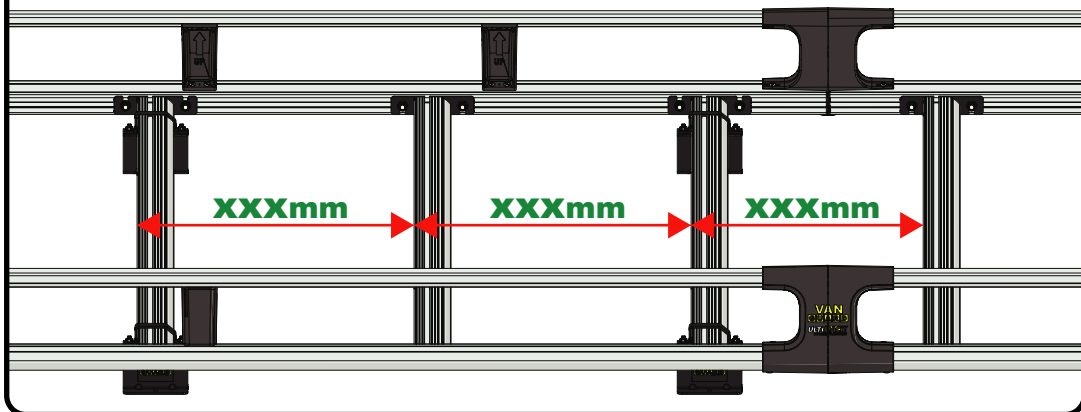
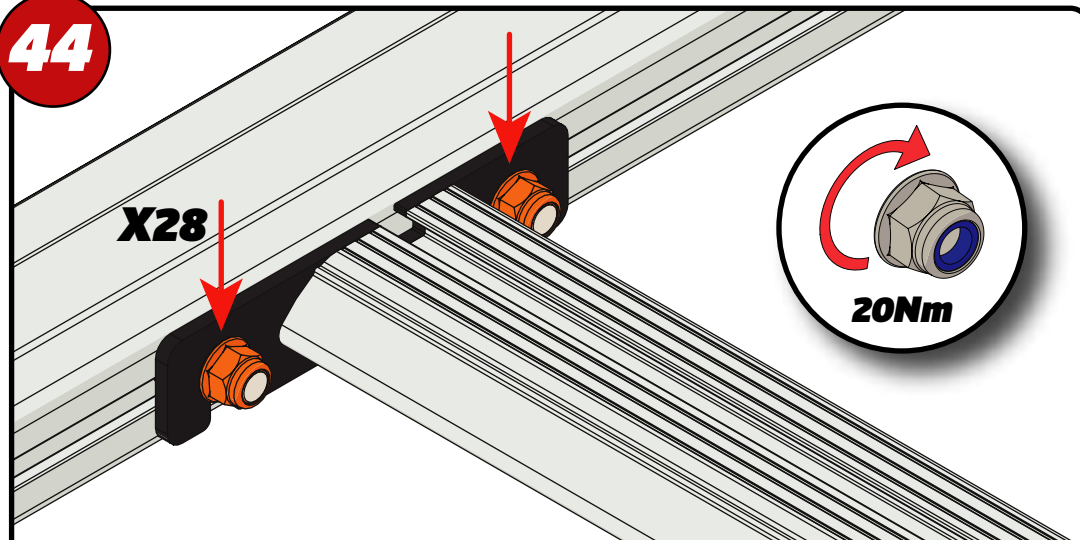
**44**

EN - TIGHTEN ALL OF THE CROSS BARS
 DE - ALLE QUERSTANGEN FESTZIEHEN
 FR - SERREZ TOUTES LES BARRES TRANSVERSALES
 NL - DRAAI ALLE DWARSBALK VAN HET DAK AAN
 ES - APRIETE TODAS LAS BARRAS TRANSVERSALES
 IT - STRINGERE TUTTE LE BARRE TRASVERSALI

SV - SKRU UPP ALLA KORSSTANGAR
 DA - SKRU ALLE TAGBØJLER OP
 NO - SKRU OPP ALLE TVERRSTENGER
 PL - DOKRĘCIĆ WSZYSTKIE POPRZECZKI
 CS - VŠECHNY PŘÍČNÉ TYČE SEŠROUJTE

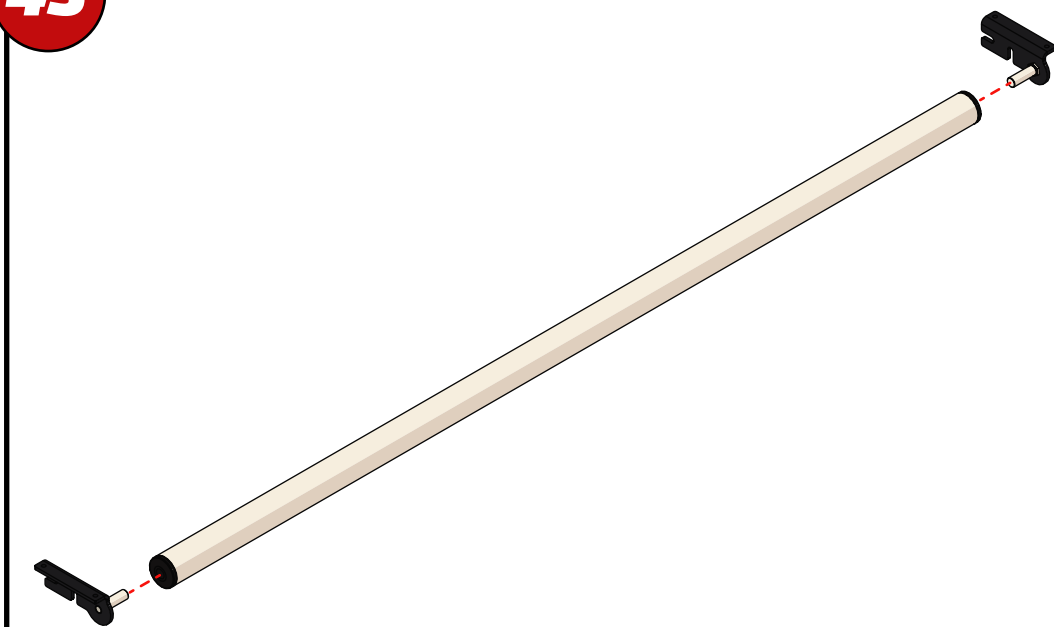
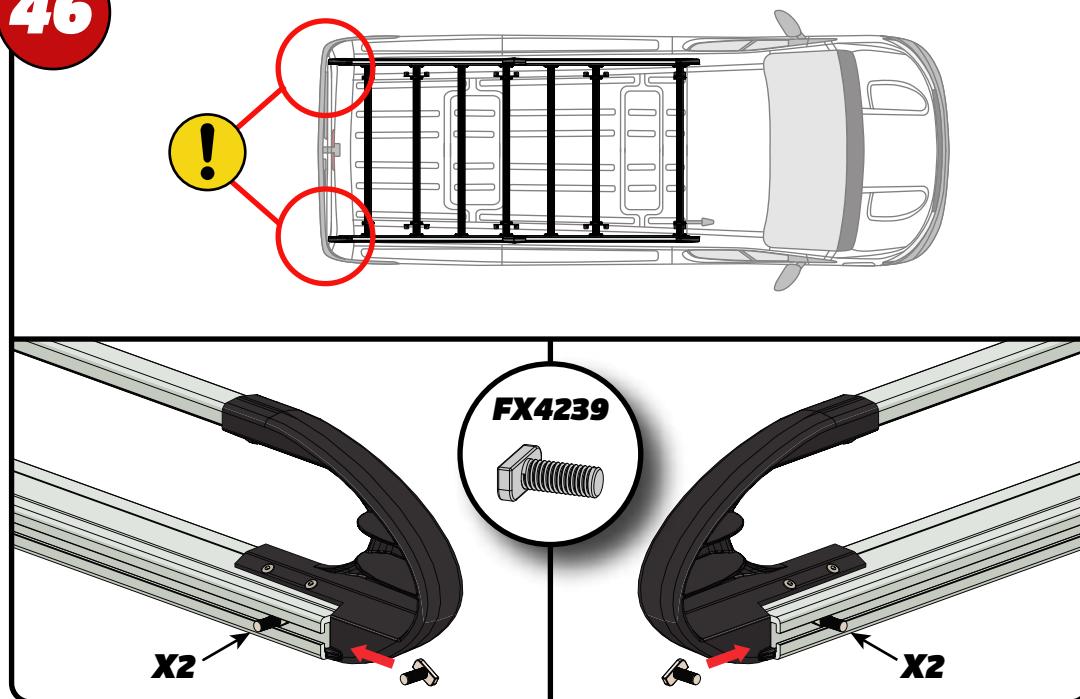
45**46**

47

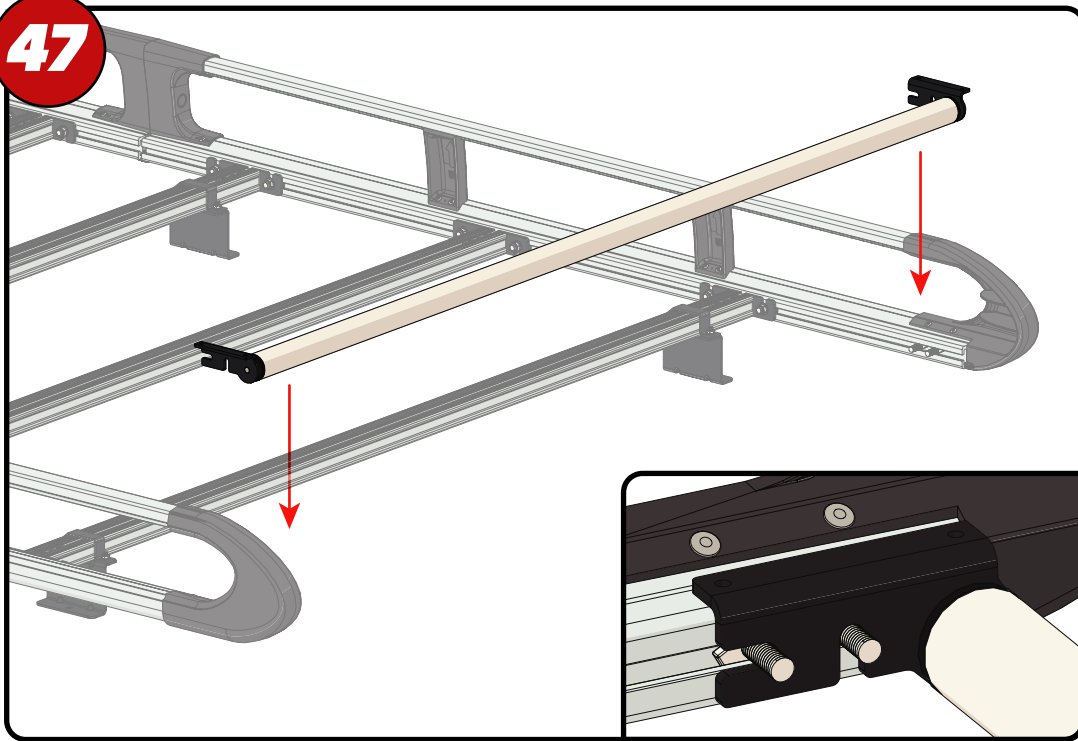

48

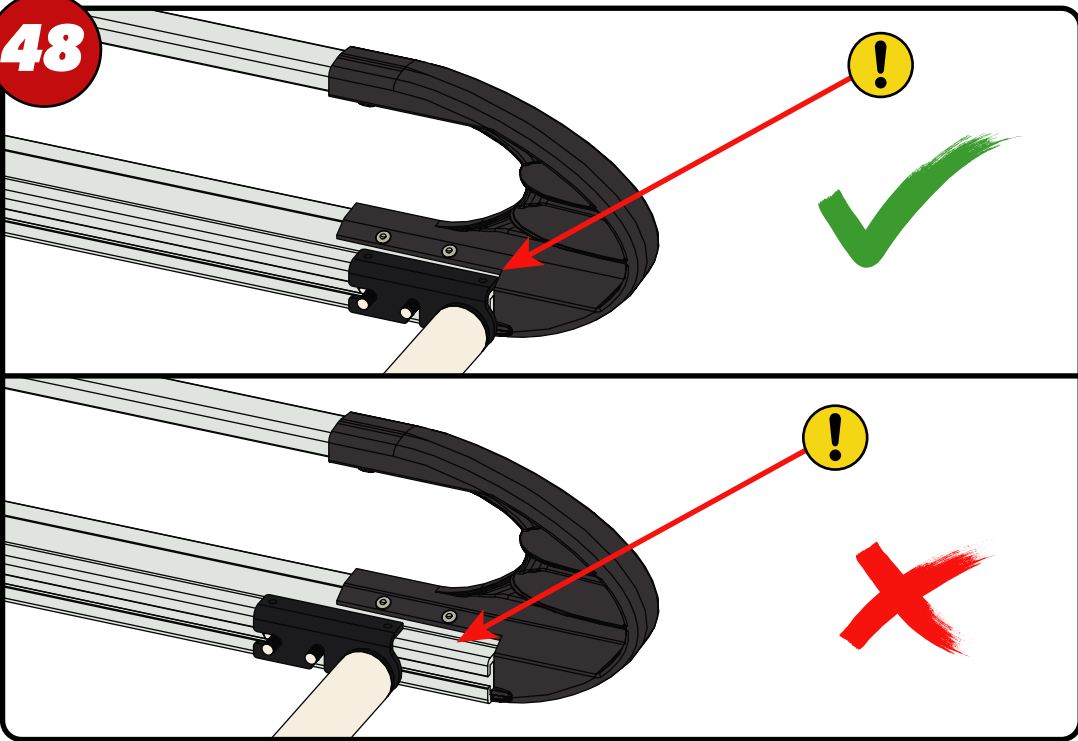

49

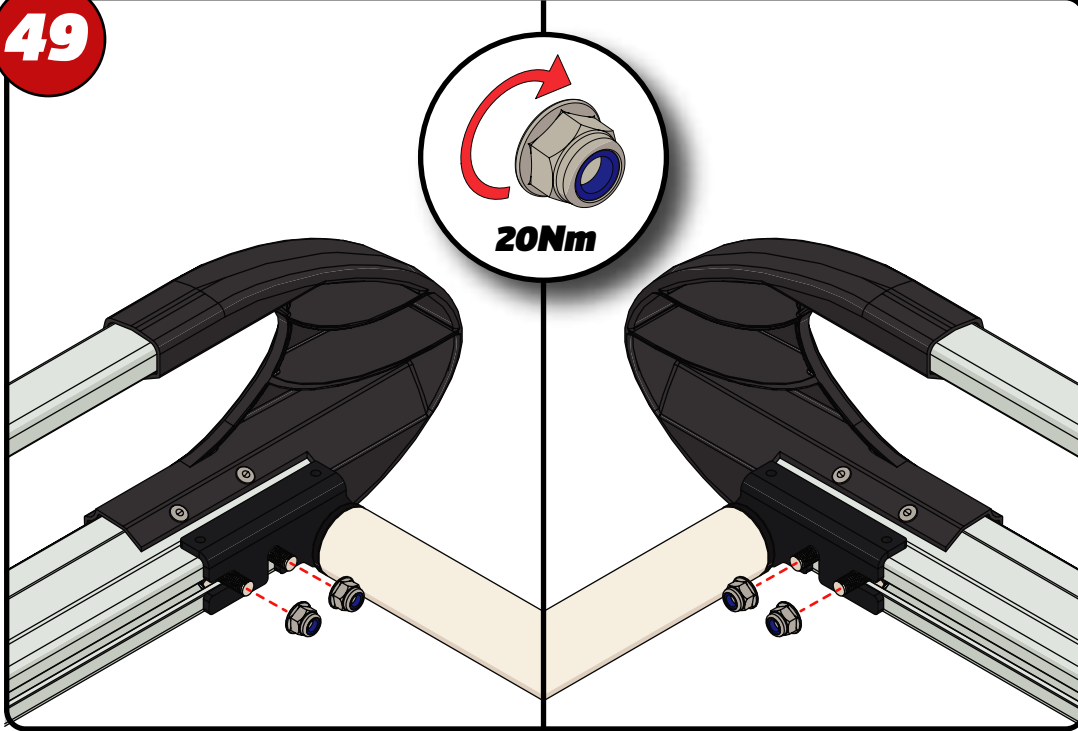

50

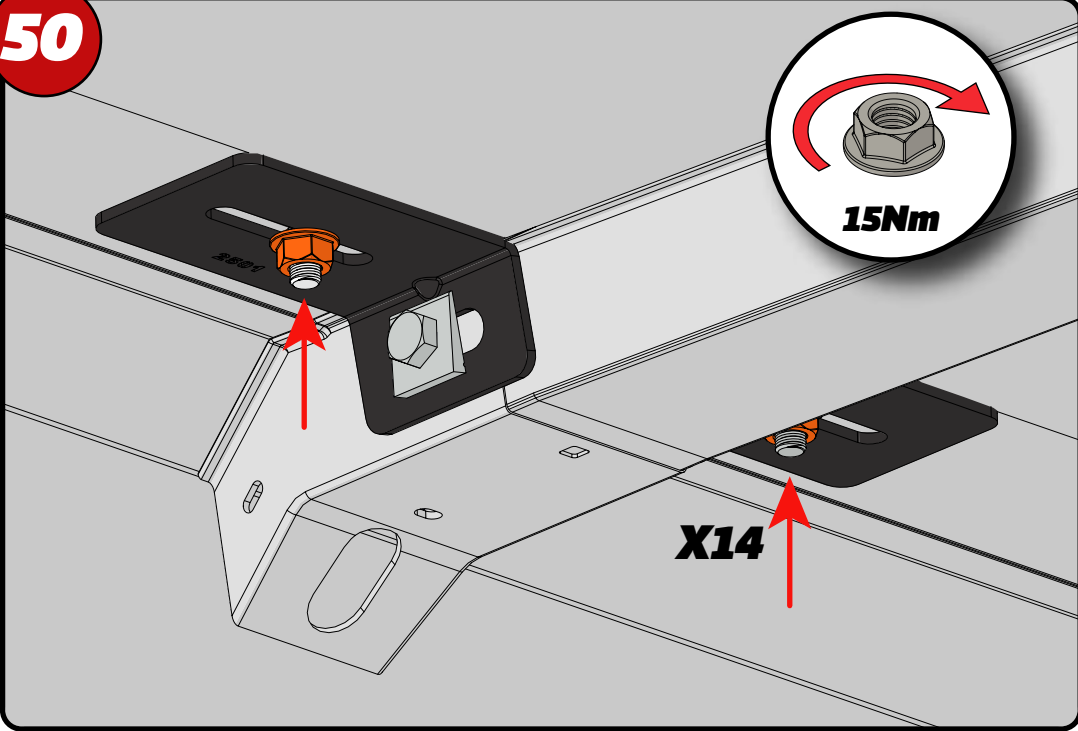

51

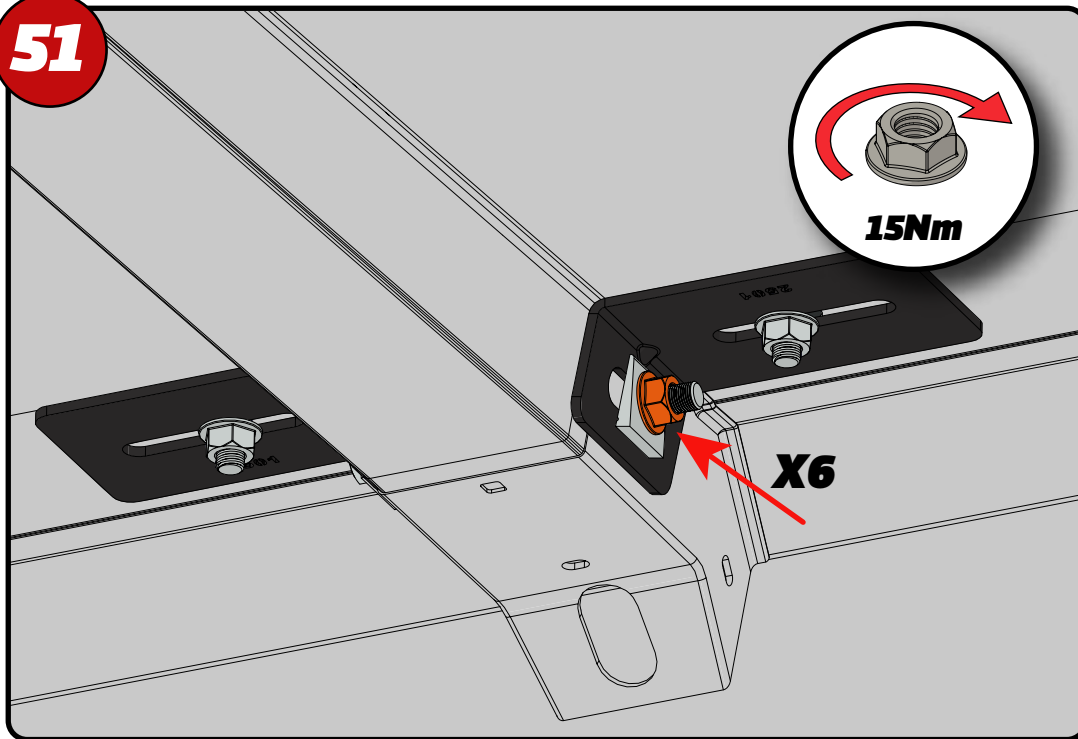

52

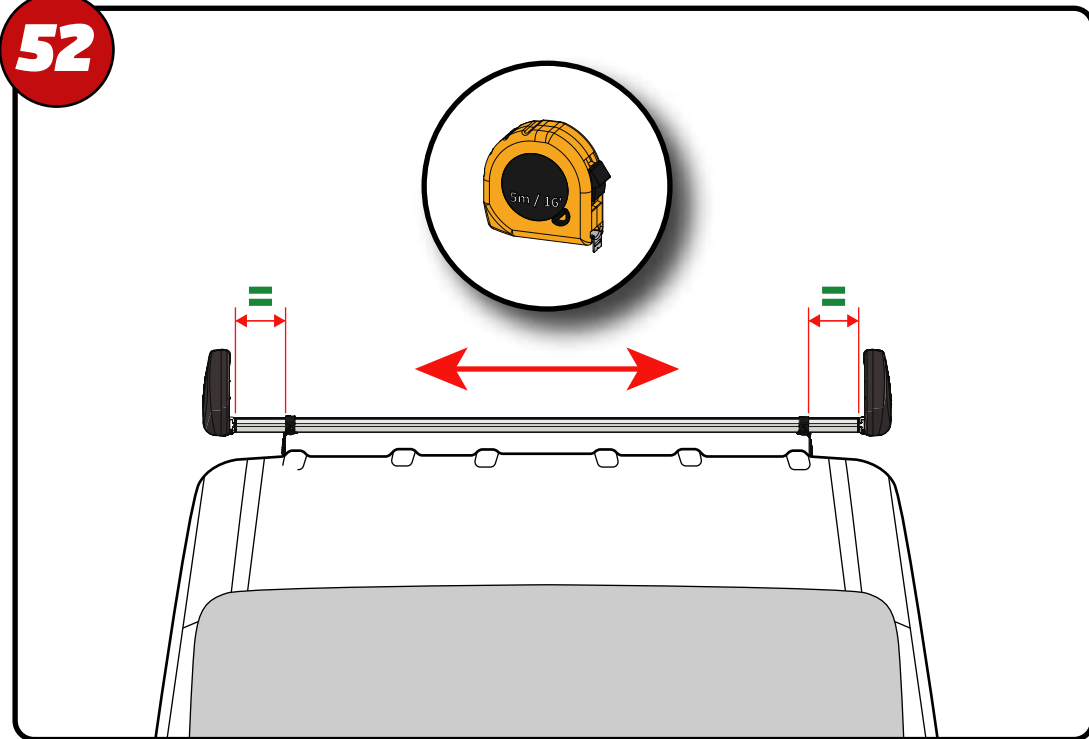

53

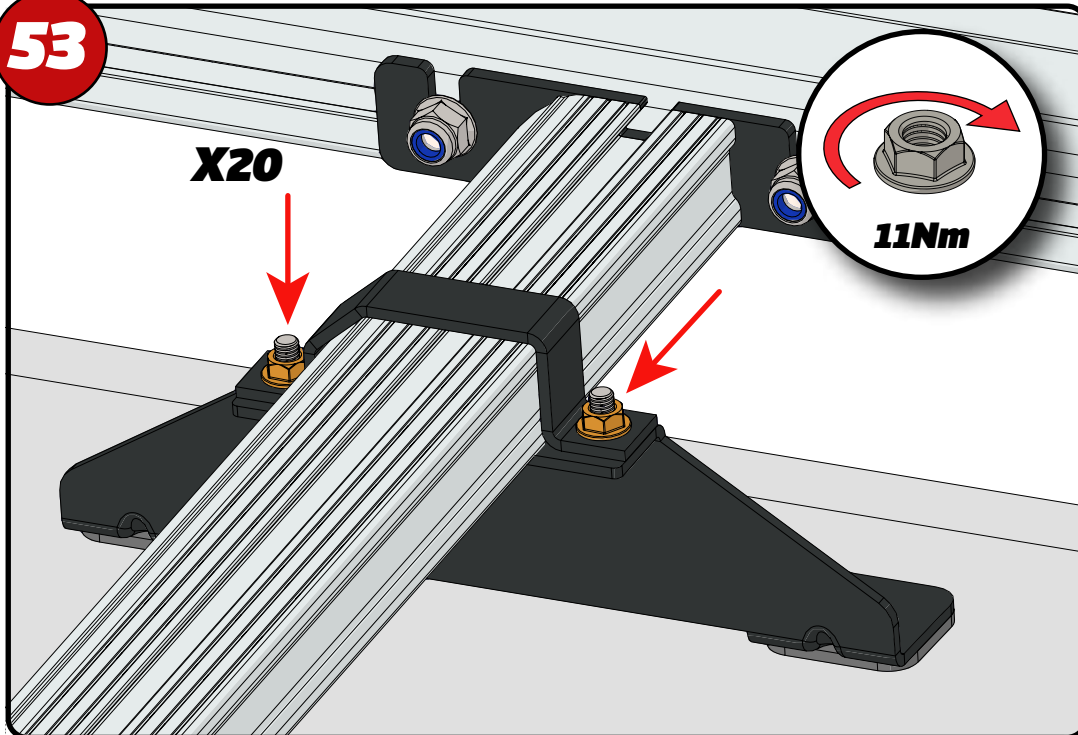

54

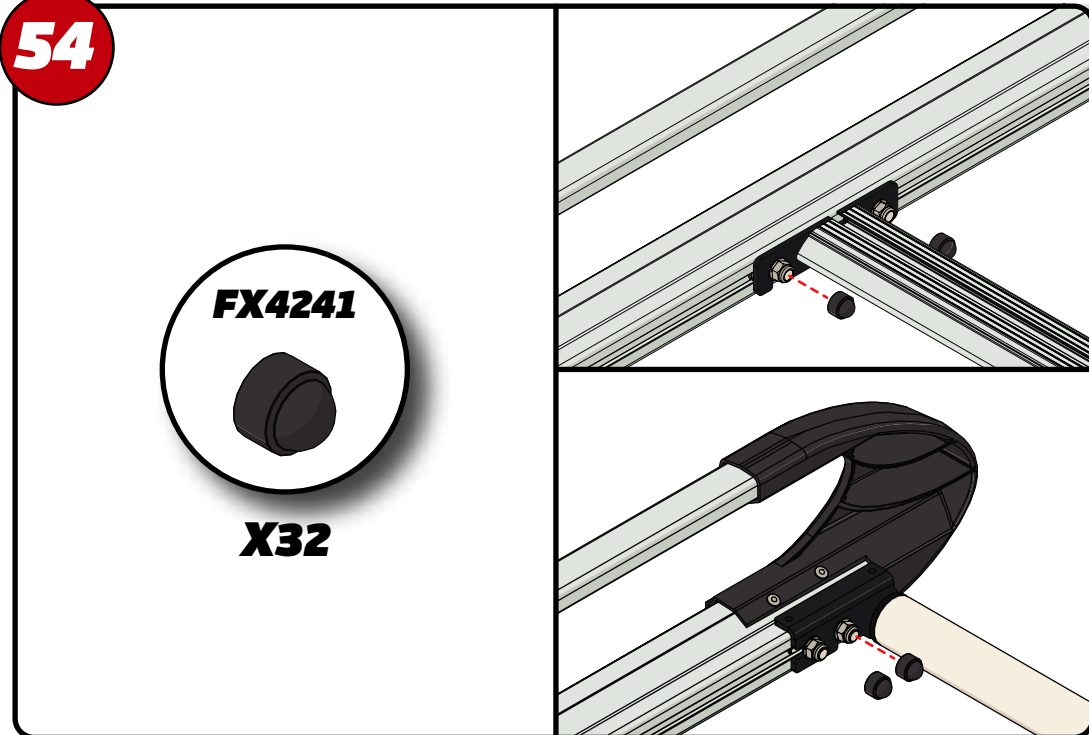

55

X10

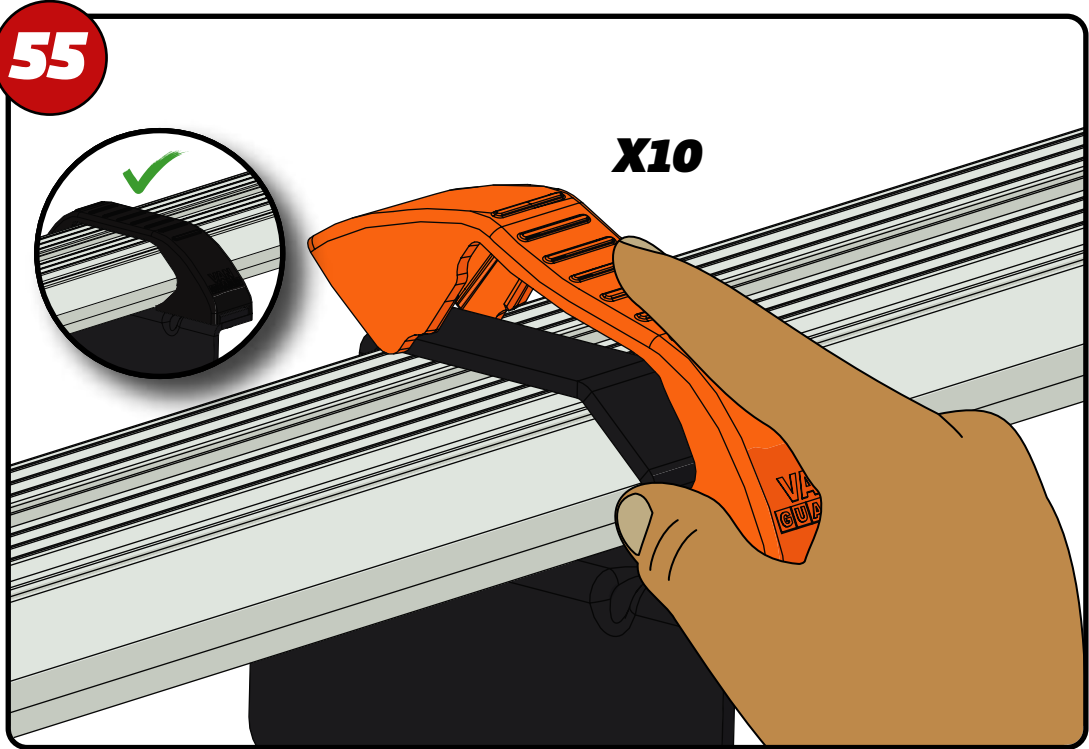

56

X4

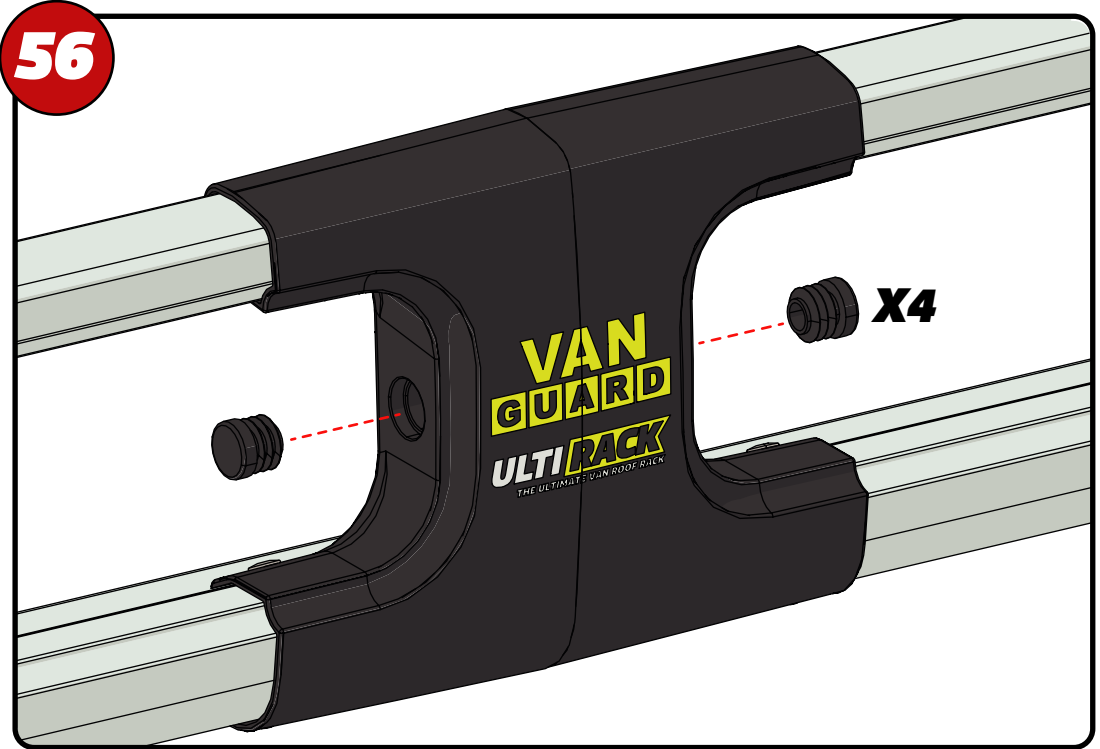

57

