

910-45x

Lv7 2021-r4

Modelo-model:

CRUZ Evo Rack Module E28

Lote-Lot-Lot-Lot:



Peso-Weight-Poids-Gewicht:

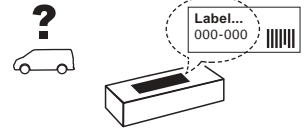

Max: 180 kg / 400 lbs



CEE - EEC type approval:



26 R- 04 3024

ES	Instrucción de montaje ¡Leer primero!	Portaequipajes
EN	Assembly instructions Read first!	Roof racks
FR	Instruction de montage Lire en premier!	Galleries
DE	Montageanleitung Zuerst lesen!	Dachgepäckträger
PT	Instruções de montagem Ler primeiro!	Porta bagagens
IT	Istruzioni di montaggio Leggere per primo!	Portabagagli
NL	Montagehandleiding Eerst lezen!	Imperiaal
PL	Instrukcja montażu Najpierw przeczytaj!	Bagażnik dachowy
CZ	Montážní návod Čtěte pozorně!	Strešní nosiče
HU	Szerelési Utasítás Először olvasd el!	Csomagtartó
HR	Detaljne upute Prvo procitaj!	Portbagaj
RO	Instructiuni de montaj Intai cititi!	Krovni nosač
RU	Инструкции по монтажу Сначала прочитайте!	Багажники на крышу
GR	Διαβάστε προσεκτικά τις Οδηγίες Συναρμολόγησης!	Μπάρες Οροφής
TR	Öncelikle montaj: Talimatlarını okuyunuz!	Taşıyıcı sistem
SI	Navodila za sestavljanje Preberite!	Strešne košare



CITY CRASH (M)





CRUZBER SAU
ES-A14018311
P.I. Las Salinas II
14960 - Rute - Spain
cruz-products.com

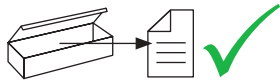

1.

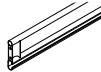

ES	Contenido embalaje: ¡Verificar!	CZ	Obsah balení: Zkontrolujte!
EN	Package content: Check!	HU	Csomag tartalma: Ellenőrizd!
FR	Contenu d'emballage: Vérifier!	HR	Sadržaj paketa: Provjeri!
DE	Packungsinhalt: Überprüfen!	RO	Pachetul contine: Verificati!
PT	Contéudo embalagem: Verificar!	RU	Содержание упаковки: Проверьте!
IT	Contenuto della confezione: Controllare!	GR	Ελέγξτε το περιεχόμενο: του πακέτου!
NL	Pakket inhoud: Controleer!	TR	Paket içeriğini: Control ediniz!
PL	Zawartość opakowania: sprawdź!	SI	Vsebina paketa: Preverite!

	910-451	910-452	910-453	910-454
	1x (738-013 DD) 1x (738-013 DI)	1x (738-013 DD) 1x (738-013 DI)	1x (738-013 DD) 1x (738-013 DI)	1x (738-013 DD) 1x (738-013 DI)
	2x (738-015T)	2x (738-015T)	2x (738-015T)	2x (738-015T)
	8x (827-412) 126 cm / 50"	8x (827-414) 140 cm / 55"	8x (827-416) 158 cm / 62"	8x (827-418) 170 cm / 67"
	1x (716-372) 126 cm / 50"	1x (716-373) 140 cm / 55"	1x (716-374) 158 cm / 62"	1x (716-375) 170 cm / 67"
	1x (805-164) 1x (805-177) 2x (855-251)	1x (805-164) 1x (805-177) 2x (855-251)	1x (805-164) 1x (805-177) 2x (855-251)	1x (805-164) 1x (805-177) 2x (855-251)
Lote / Lot	02-21	02-21	02-21	02-21
 Peso / Weight	21,05 kg 46,4 lbs	25,00 kg 55,1 lbs	26,26 kg 58 lbs	27,26 kg 60,1 lbs

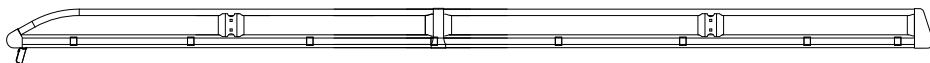

2. 

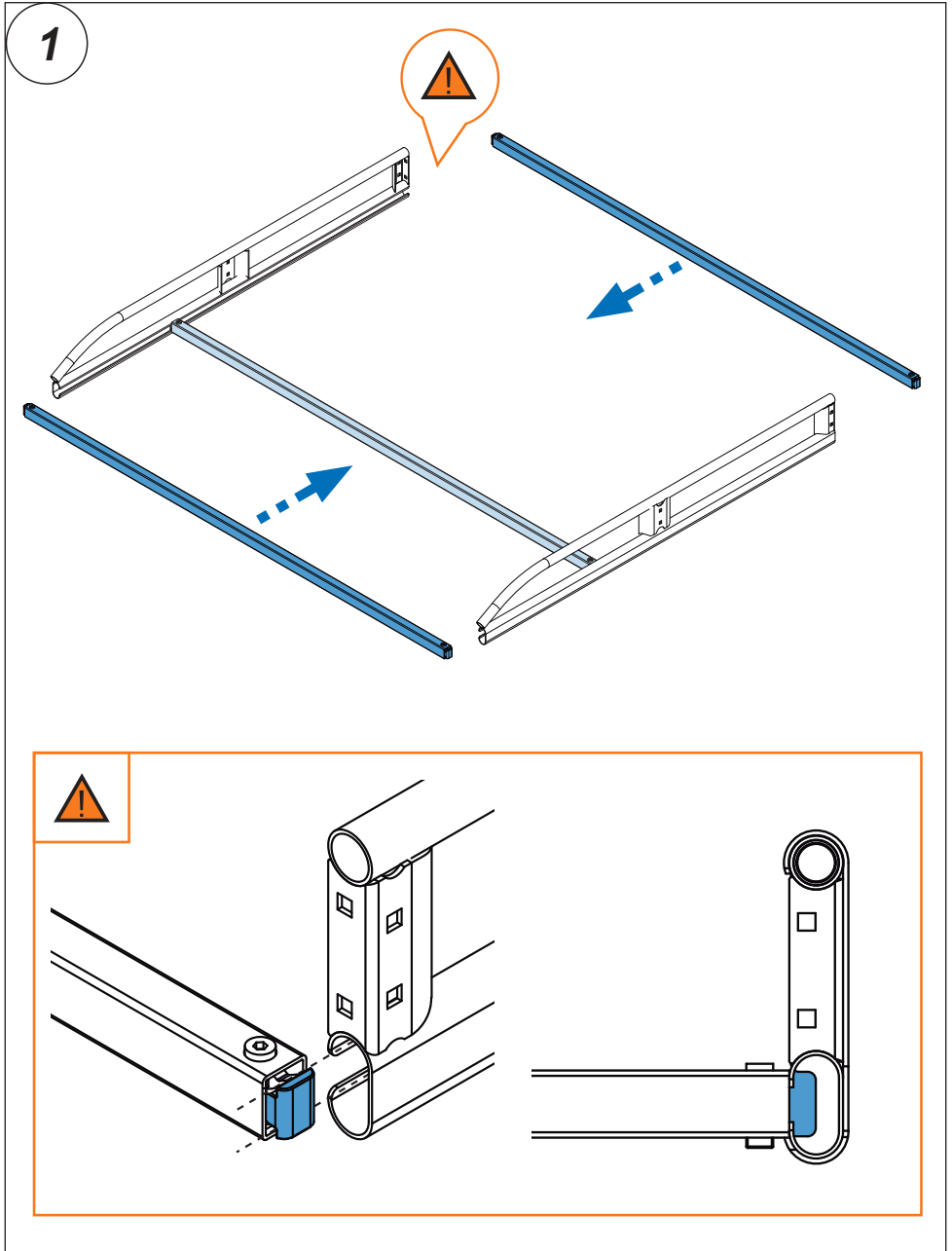

3. 

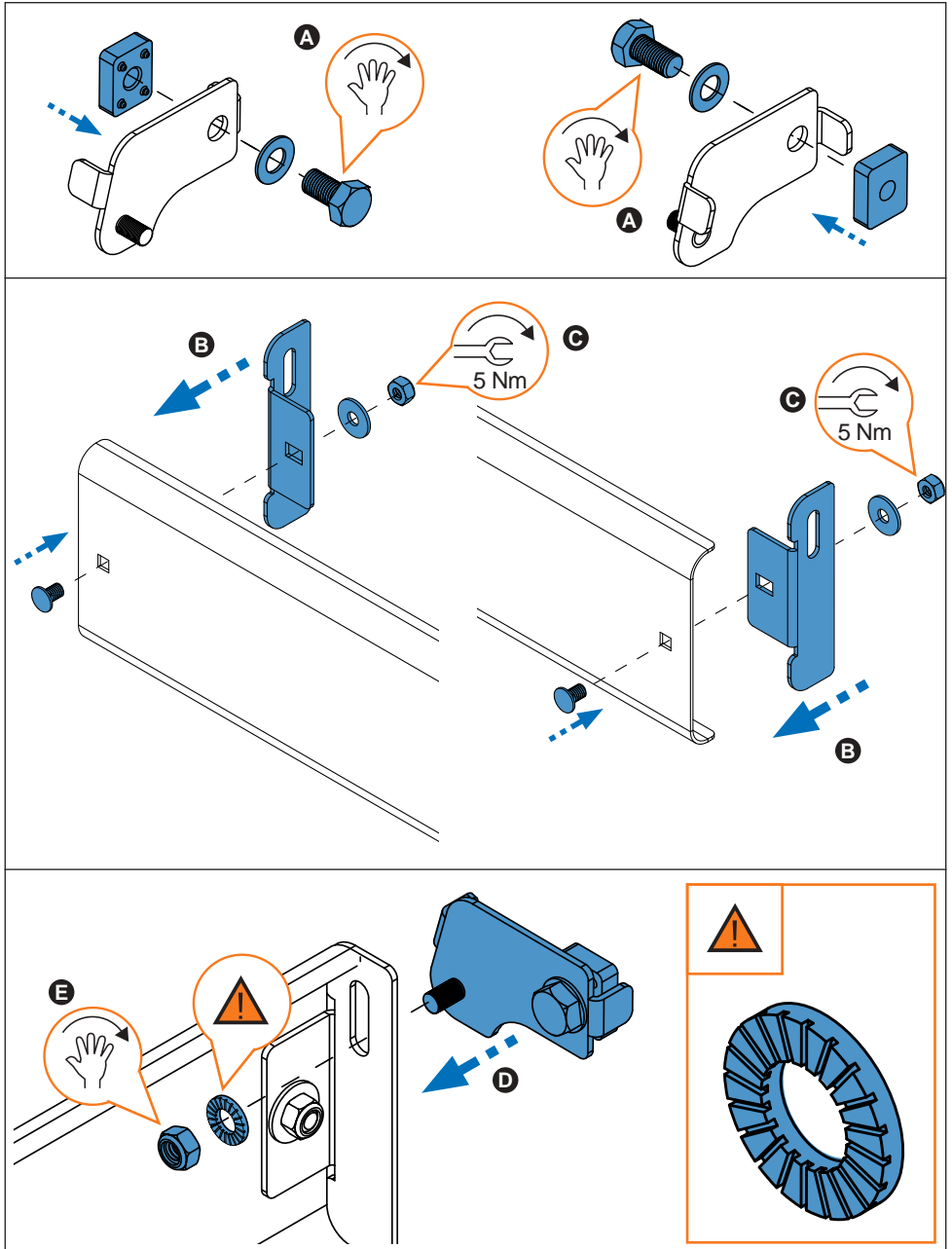

4. 

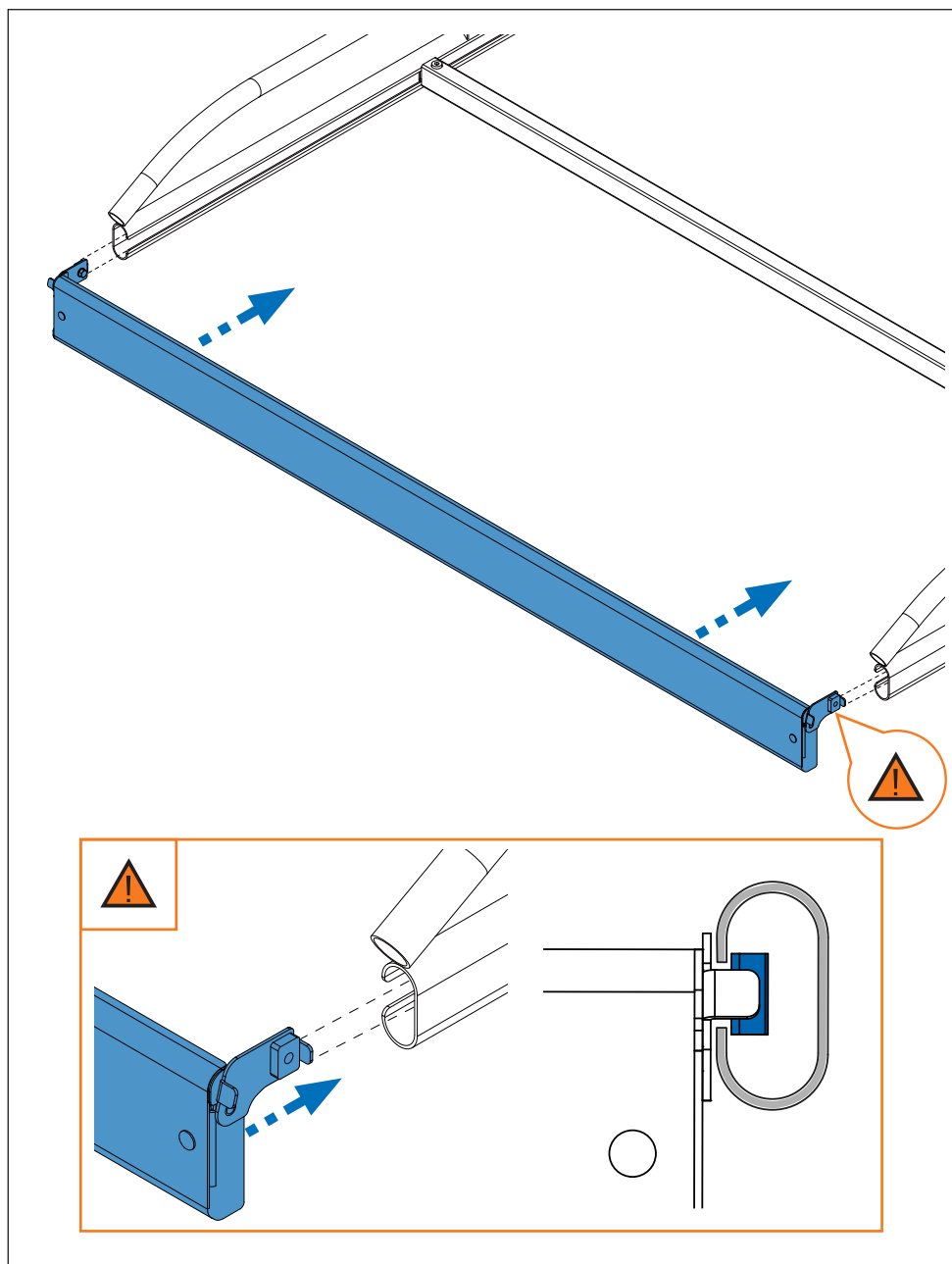

5. 

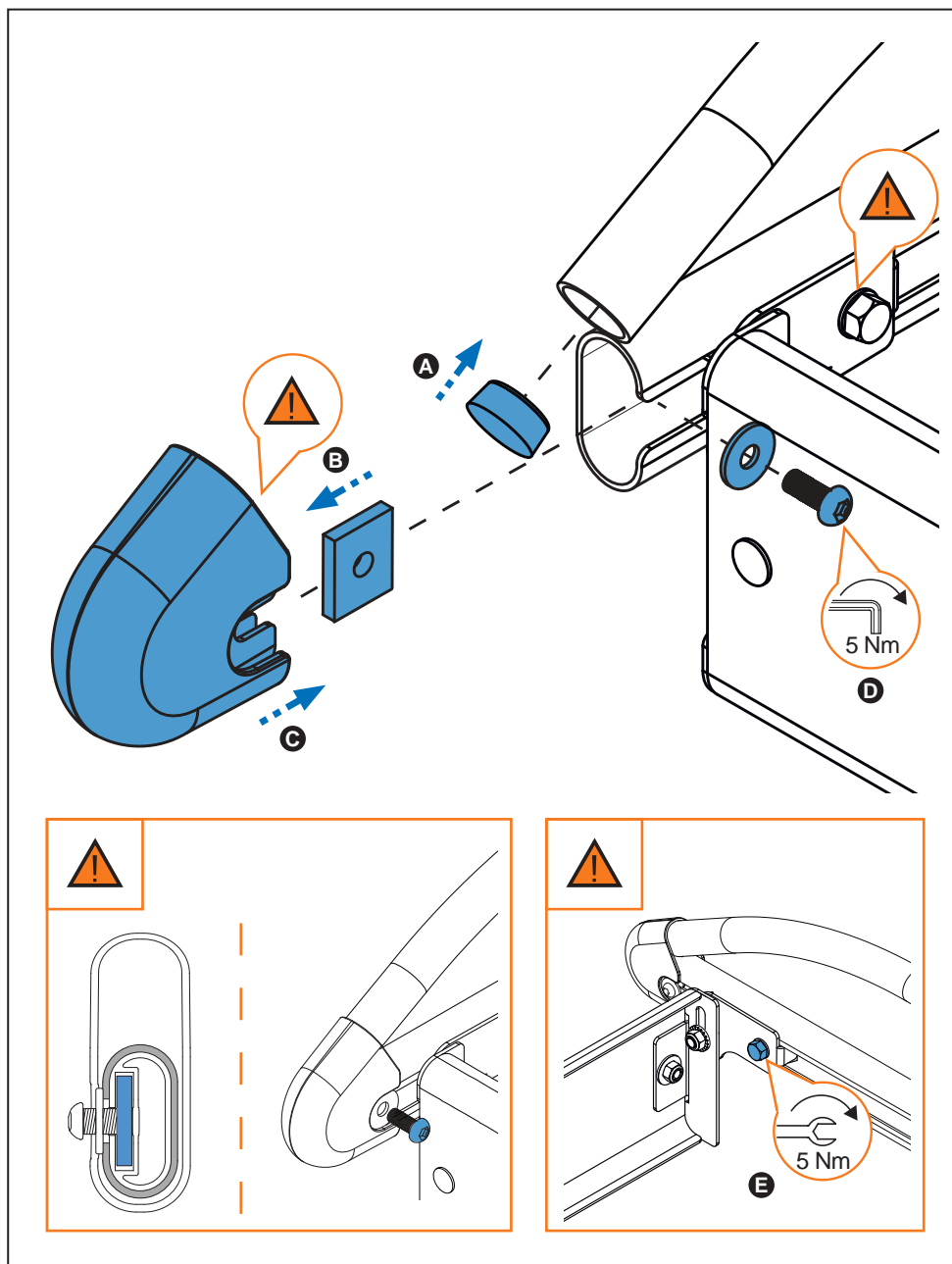

6. 

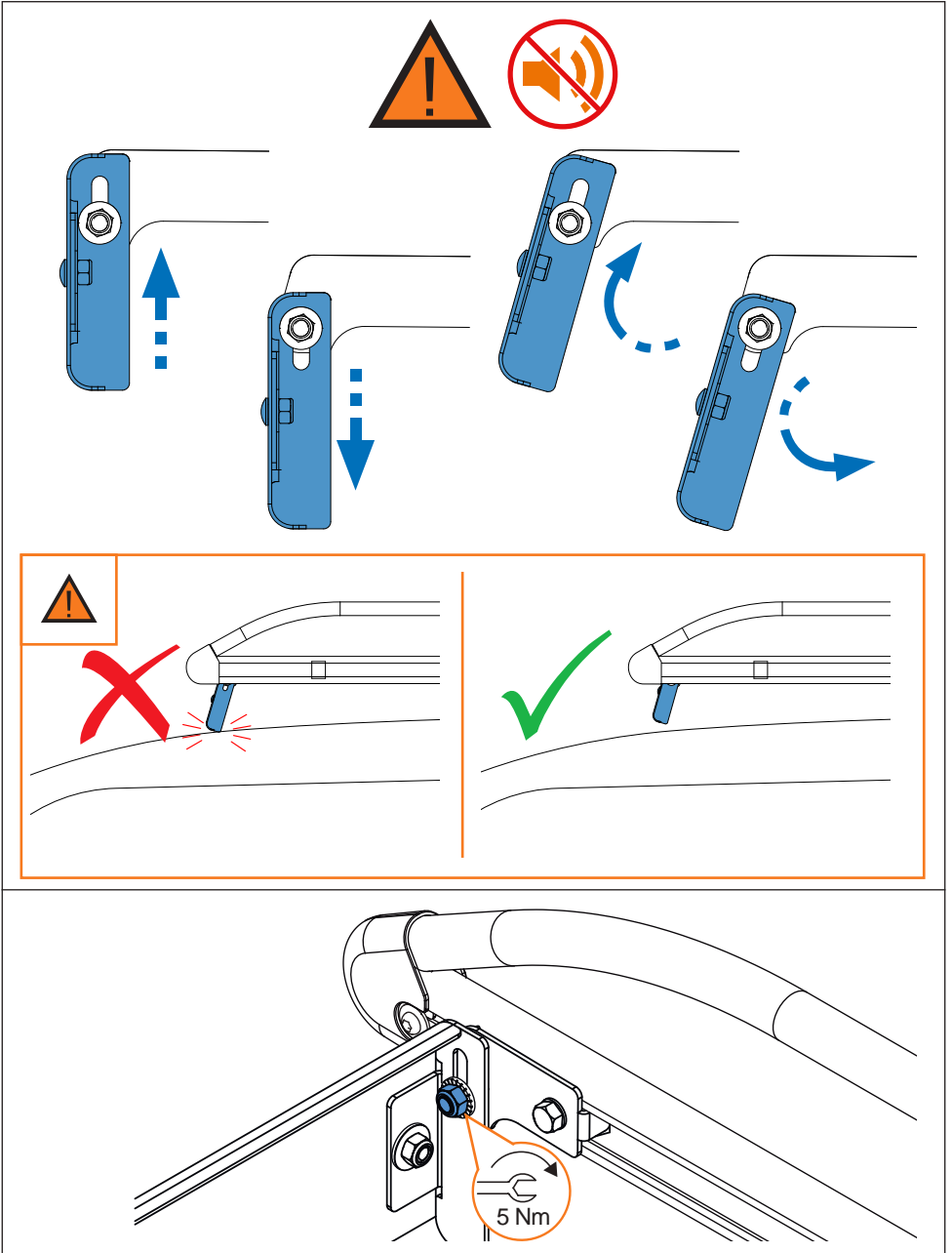

7. 

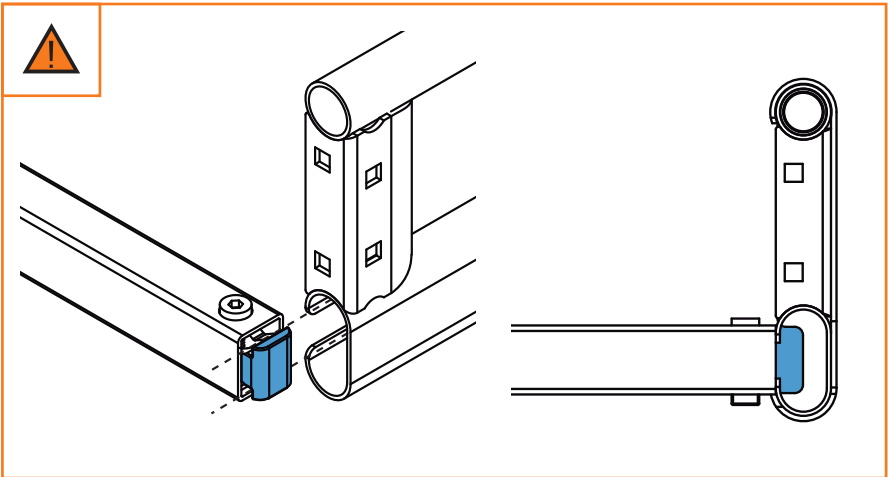
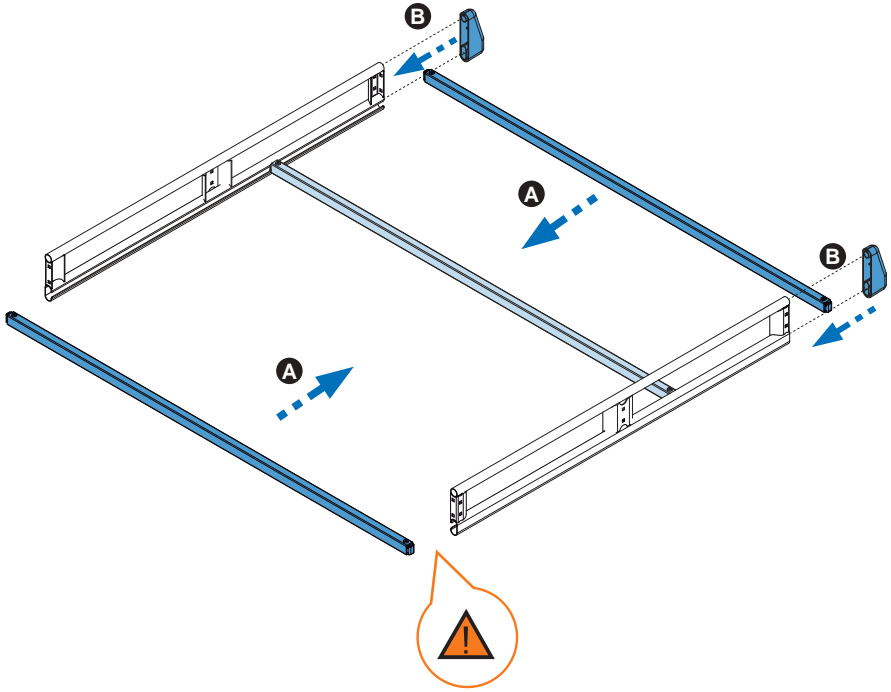

8. 

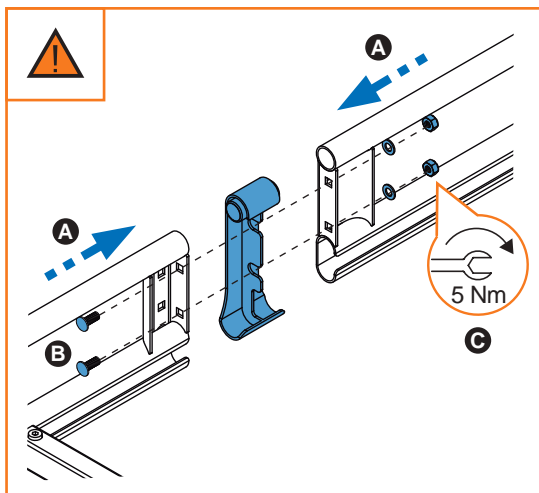
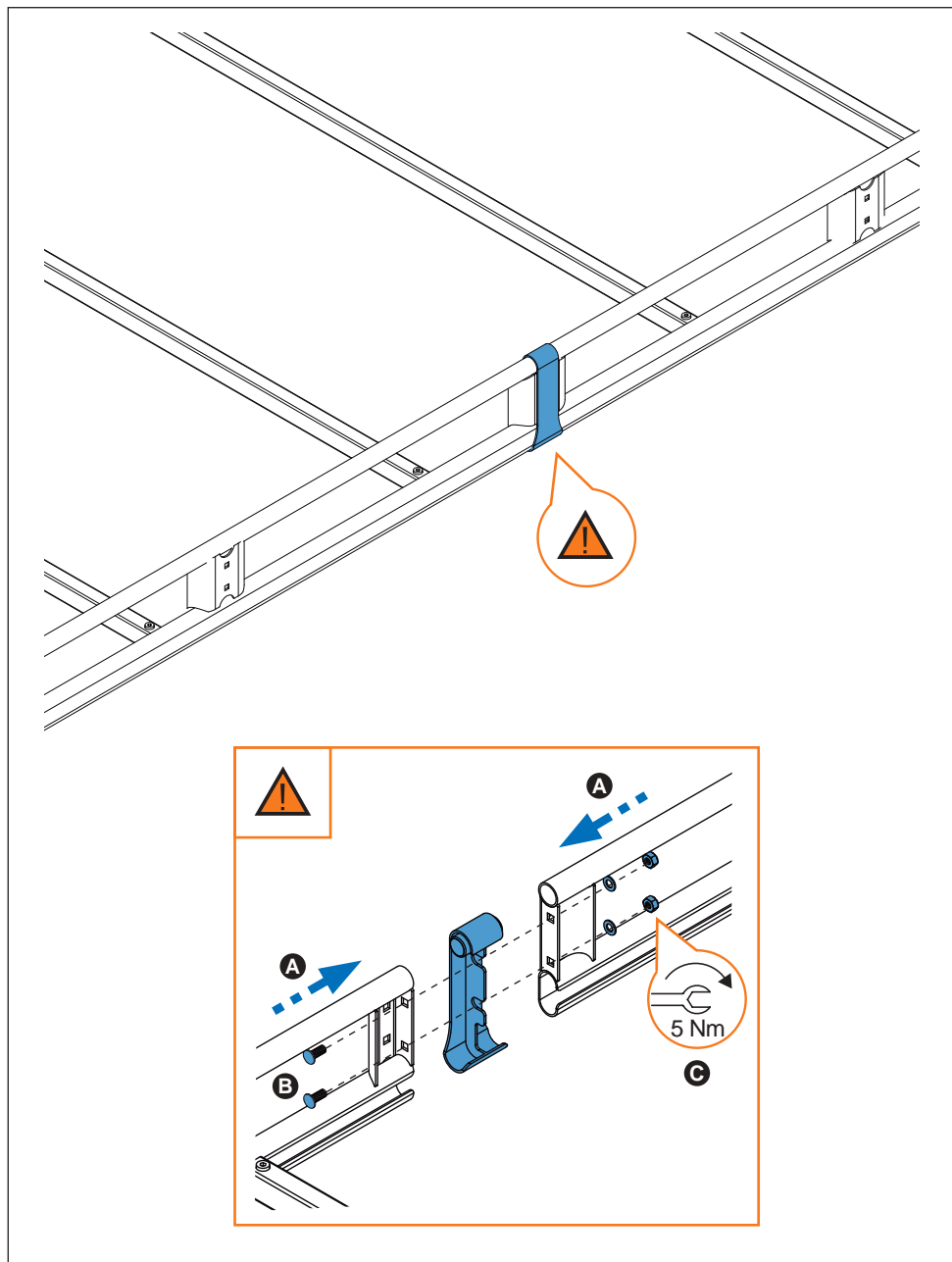

9. 

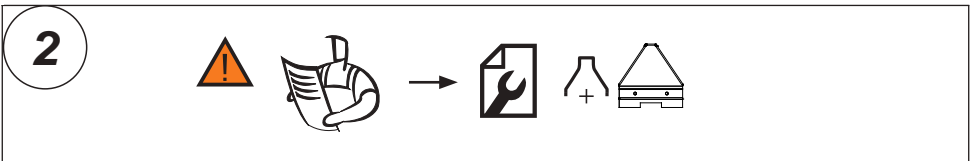
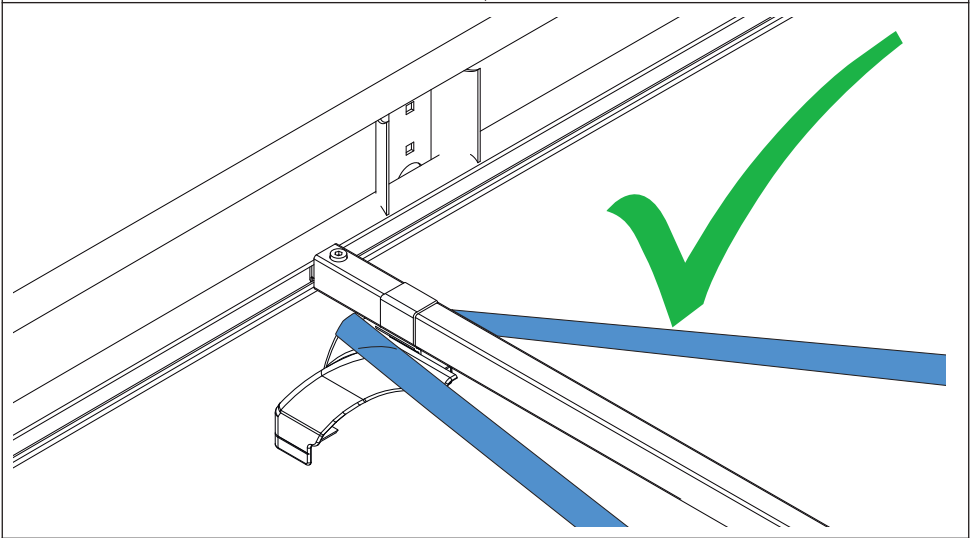
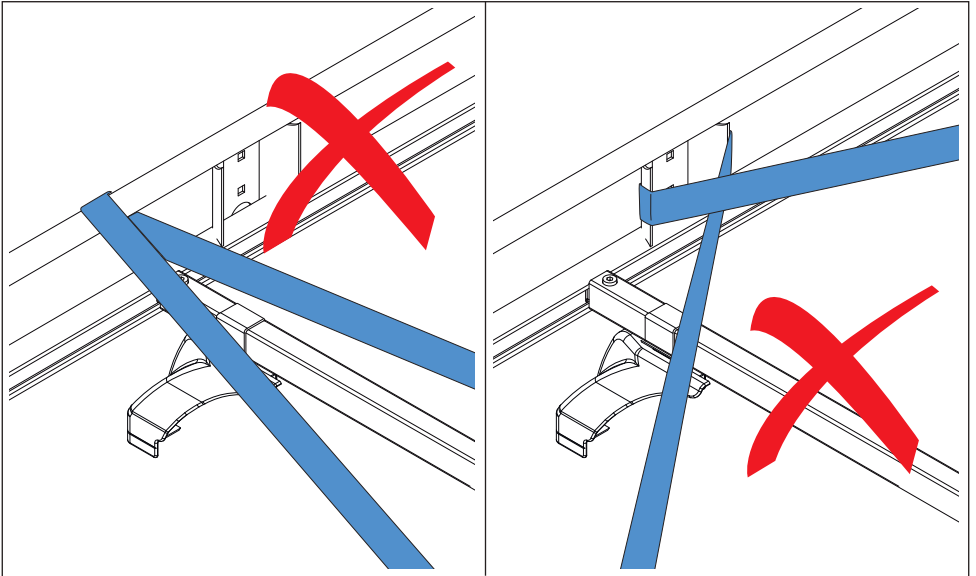

ES	Instrucción de montaje ¡Leer primero!	Kit fijación
EN	Assembly instructions Read first!	Fixation Kit
FR	Instruction de montage Lire en premier!	Kit fixation
DE	Montageanleitung Zuerst lesen!	Stützfuß-Kit
PT	Instruções de montagem Ler primeiro!	Kit fixação
IT	Istruzioni di montaggio Leggere per primo!	Kit di fissaggio
NL	Montagehandleiding Eerst lezen!	Bevestigingsset
PL	Instrukcja montażu Najpierw przeczytaj!	Element mocujący
CZ	Montážní návod Čtěte pozorně!	Fixační kit
HU	Szerelési Utasítás Először olvassd el!	Rögzítő készlet
HR	Detaljne upute Prvo procitaj!	Kit za montažu
RO	Instructiuni de montaj Intai cititi!	Kit de fixare
RU	Инструкции по монтажу Сначала прочитайте!	Крепежный комплект
GR	Διαβάστε προσεκτικά τις Οδηγίες Συναρμολόγησης!	Κιβώτιο (Kit) Επίσκευής
TR	Öncelikle montaj: Talimatlarını okuyunuz!	Montaj kiti
SI	Navodila za sestavljanje Preberite!	Kit za pričvrstitev

934-404

Lv7 2021-r2

Modelo-model:

Kit 6 soportes CRUZ LCV

Lote-Lot-Lot-Lot:

01-18

Peso-Weight-Poids-Gewicht:

2,95 kg / 6,50 lbs

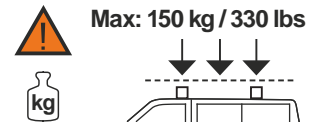
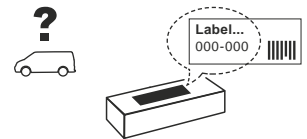

CEE - EEC type approval:

E9 26 R- 04 3022

E9 26 R- 04 3024



CITY CRASH (M)

CRUZBER SAU
ES-A14018311
P.I. Las Salinas II
14960 - Rute - Spain
www.cruz-products.com



1.

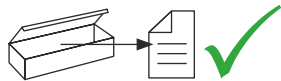

ES Contenido embalaje: ¡Verificar!

x1



x6

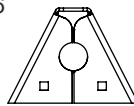

(500)

EN Package content: Check!

FR Contenu d'emballage: Vérifier!

DE Packungsinhalt: Überprüfen!

PT Contéudo embalagem:
Verificar!

x6

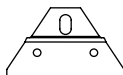

x6

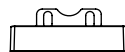

IT Contenuto della confezione:
Controllare!

NL Pakket inhoud: Controleer!

4x (841)

4x (012-231)

PL Zawartość opakowania:
sprawdź!

2x (842)

2x (012-232)

CZ Obsah balení: Zkontrolujte!

HU Csomag tartalma: Ellenőrizd!

x6

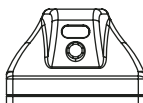

x3



HR Sadržaj paketa: Provjeri!

RO Pachetul contine: Verificati!

4x (813-073)

1x (805-025)

RU Содержание упаковки:
Проверьте!

2x (813-074)

1x (810-181)

GR Ελέγξτε το περιεχόμενο του
πακέτου!

1x (810-183)

TR Paket içeriğini: Kontrol ediniz!

SI Vsebina paketa: Preverite!

2. 

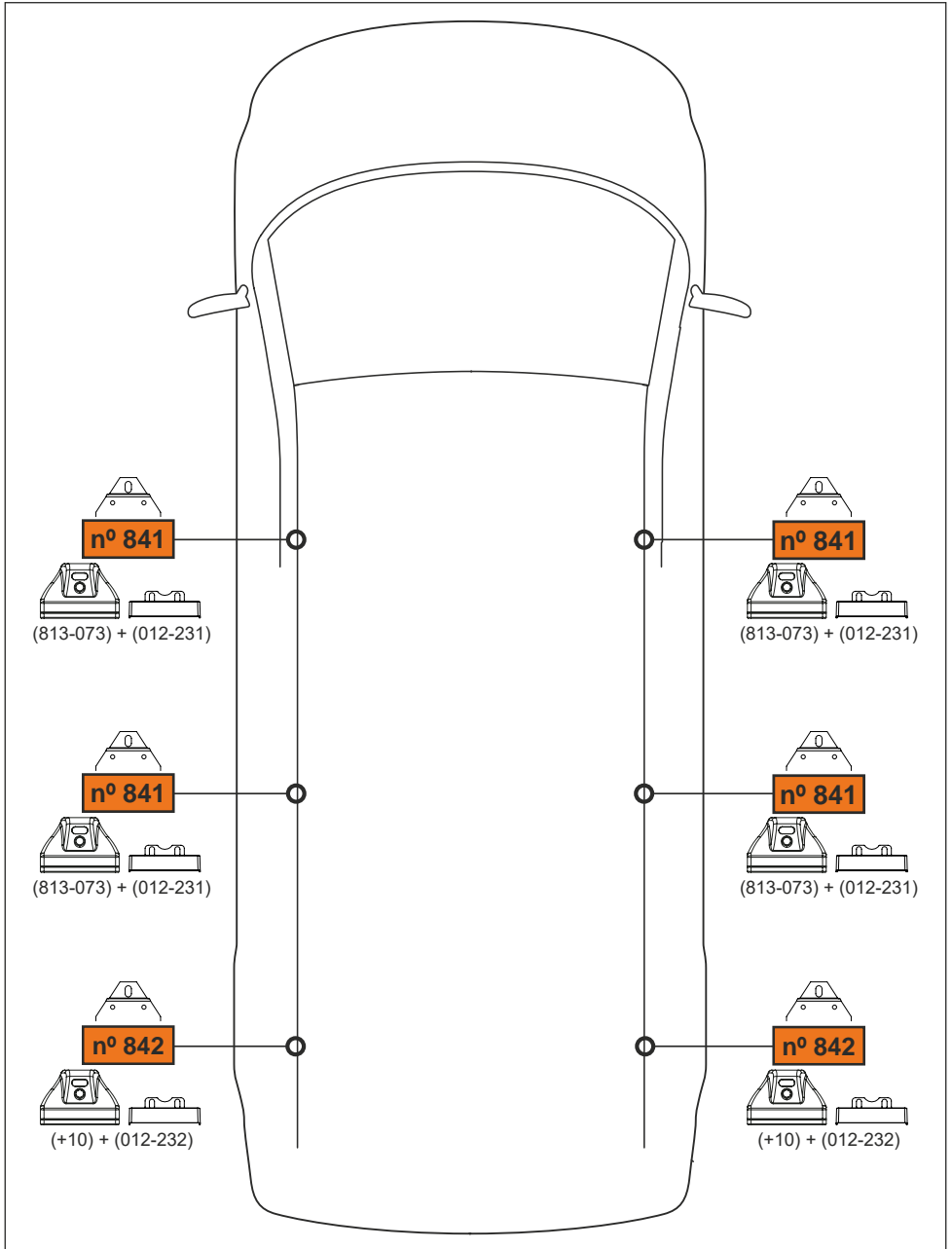

3. 

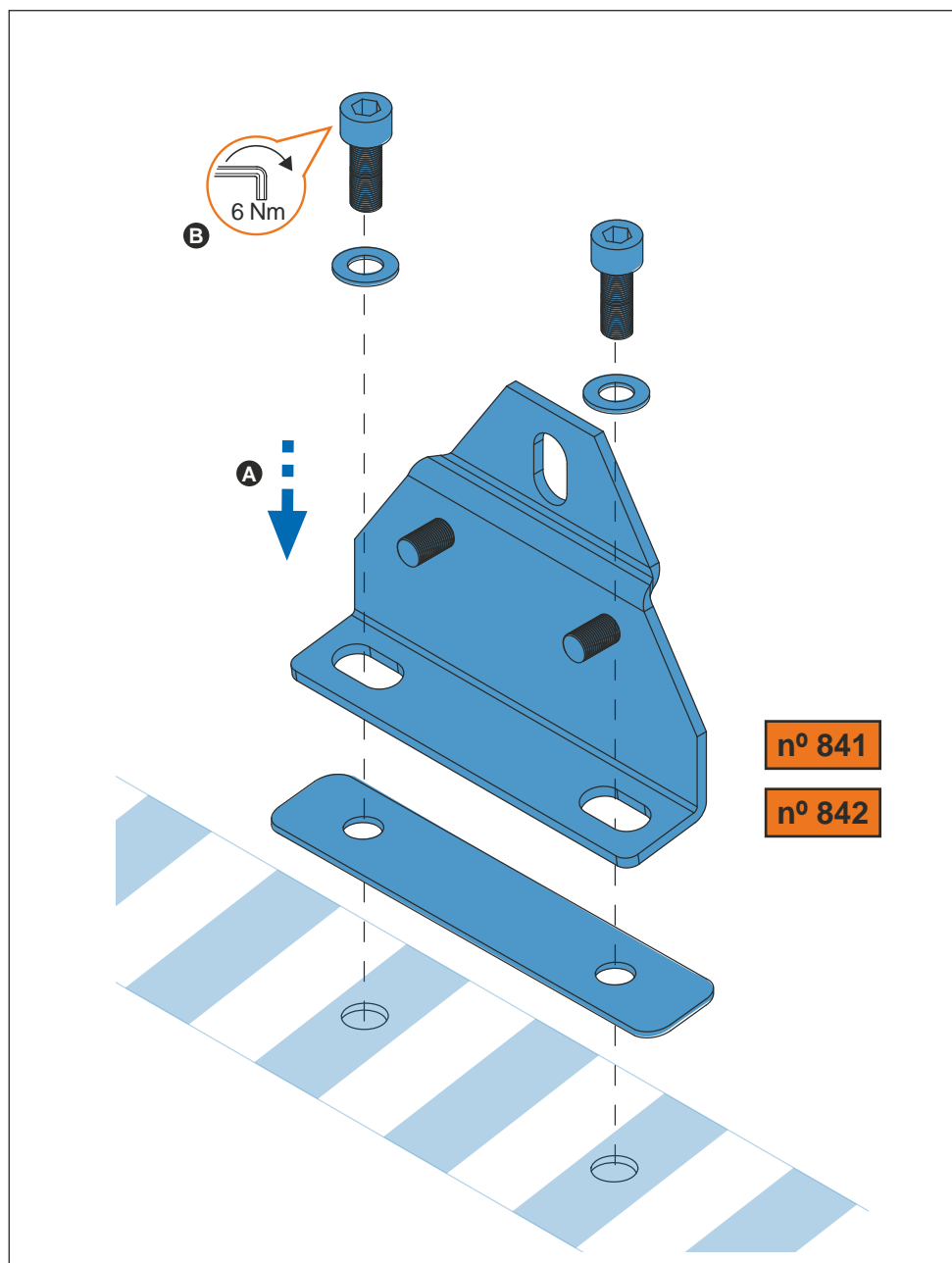

4. 



L1

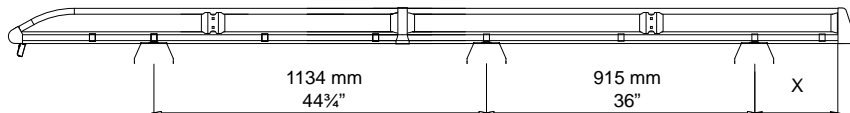

L2

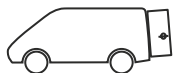
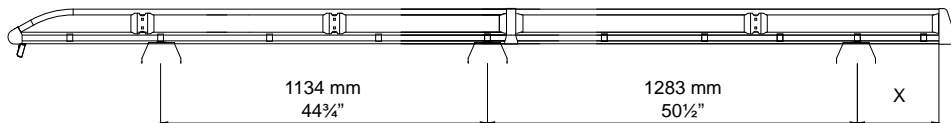

X = 285 mm
11 1/4"

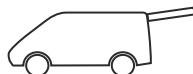

X = 105 mm
4 1/4"



OPTIONAL
OPCIONAL

941-109

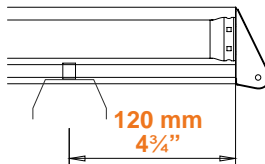
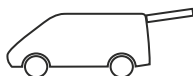
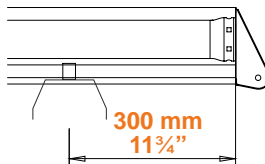
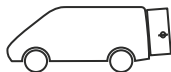

5. 

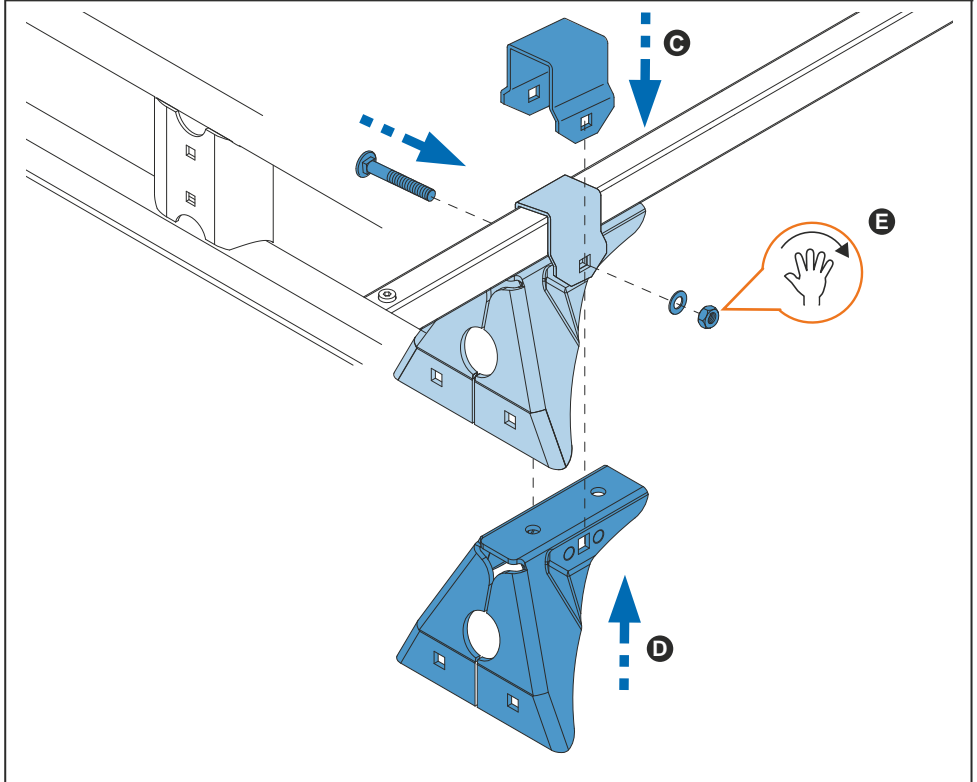
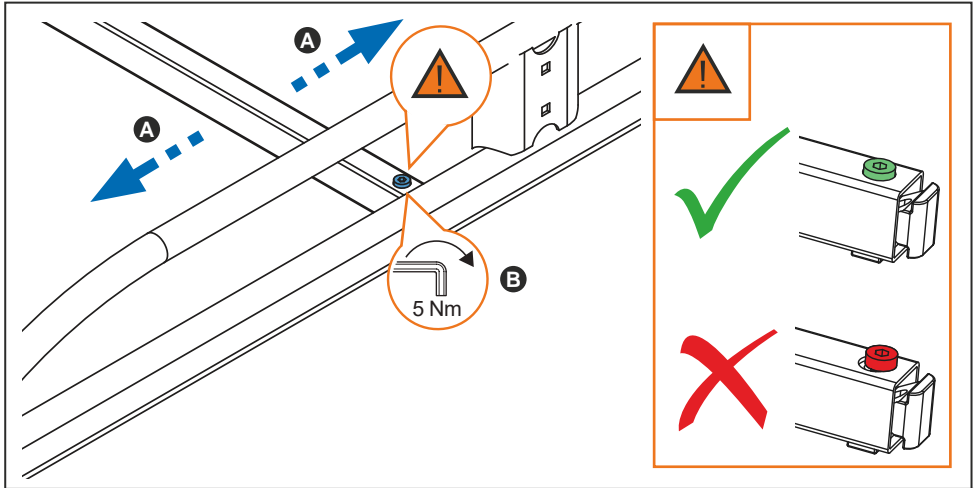

6.

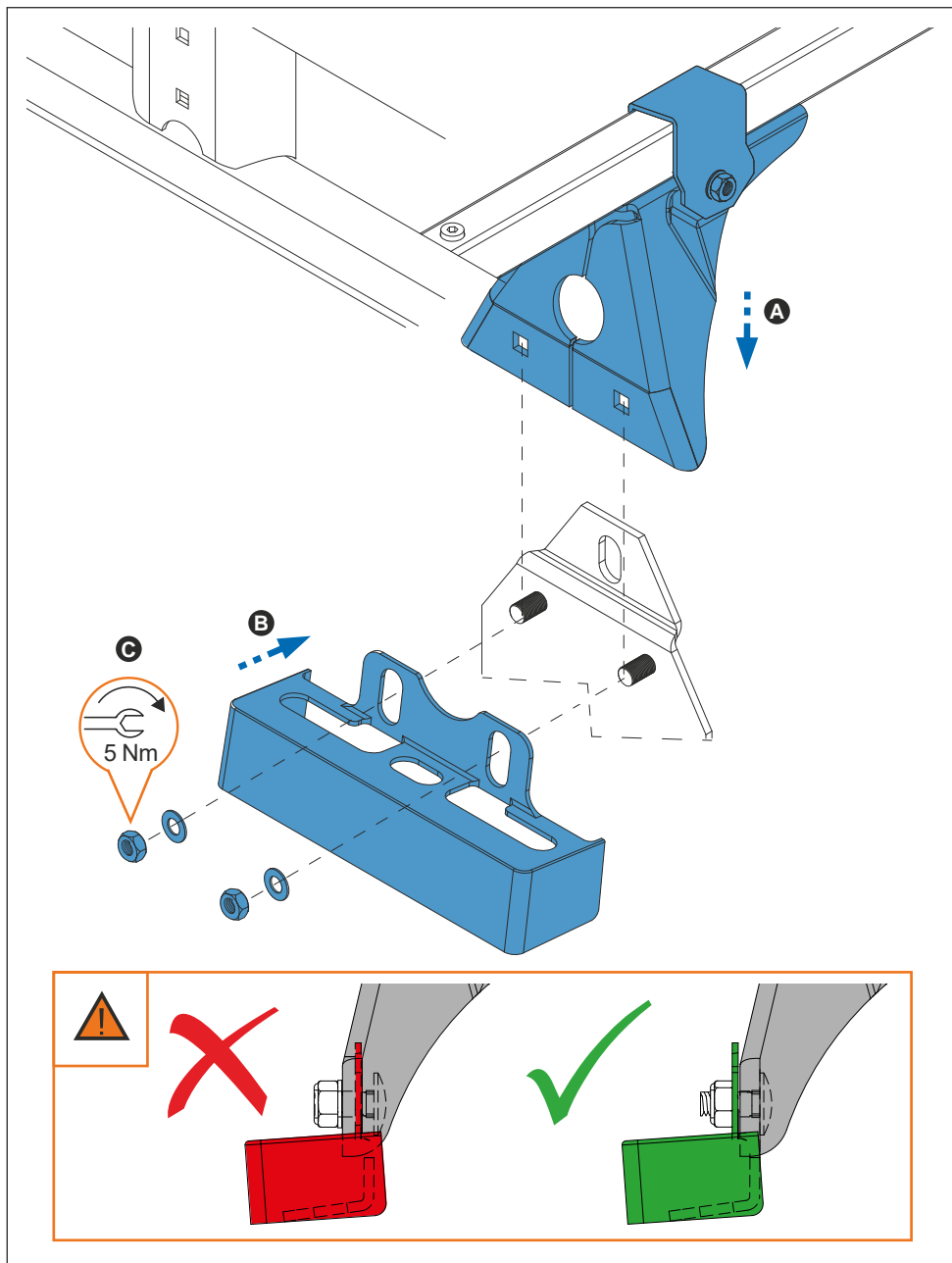

7.

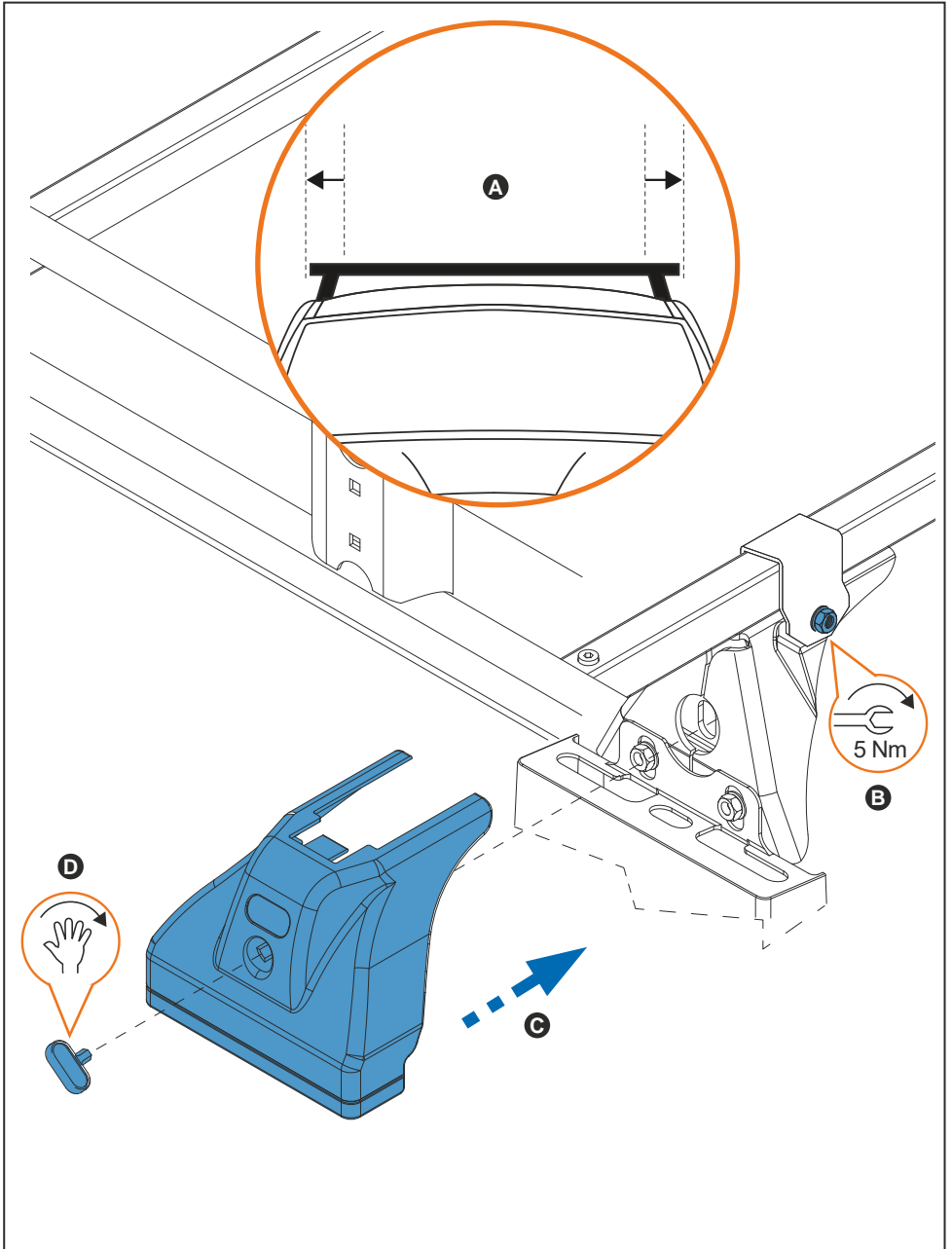

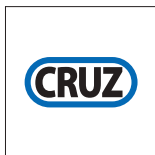

941-109

Lv7 2019-r3

Modelo-model:

Evo Rack

Lote-Lot-Lot-Lot:

01-16

Peso-Weight-Poids-Gewicht:

0,50 kg / 1,10 lbs

ES	Instrucción de montaje ¡Leer primero!	Soportes Rulo
EN	Assembly instructions Read first!	Roller supports
FR	Instruction de montage Lire en premier!	Supports rouleau
DE	Montageanleitung Zuerst lesen!	Laderollenhalter
PT	Instruções de montagem Ler primeiro!	Soportes rolamento
IT	Istruzioni di montaggio Leggere per primo!	Supporti per rulli
NL	Montagehandleiding Eerst lezen!	Ladderrol steunen
PL	Instrukcja montażu Najpierw przeczytaj!	Wsporniki rolki
CZ	Montážní návod Čtěte pozorně!	Výztuž válce
HU	Szerelési Utasítás Először olvasd el!	Görgő tartó
HR	Detaljne upute Prvo pročitati!	Valjkasti podupirači
RO	Instructiuni de montaj Intai cititi!	Suporturi pentru rola
RU	Инструкции по монтажу Сначала прочитайте!	Крепление для ролика
GR	Διαβάστε προσεκτικά τις Οδηγίες Συναρμολόγησης!	Στηρίγματα για ρόλλερ
TR	Öncelikle montaj: Talimatlarını okuyunuz!	Silindir destekliyciler
SI	Navodila za sestavljanje Preberite!	Podpore za roler

CRUZBER SAU
ES-A14018311
P.I. Las Salinas II
14960 - Rute - Spain
cruz-products.com



1.

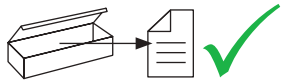

x1



x1



x1



(810-141)

x1



(718-141)
izquierdo/left

x1

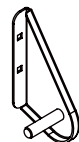

(718-140)
derecho/right



Importante!
Important!
Important!
Wichtig!

IT Questo accessorio deve essere utilizzato con i sistemi a barre CRUZ!

RO Această accesoriu trebuie utilizat, cu sisteme CRUZ!

ES ¡Este accesorio tiene que usarse con sistemas portacargas CRUZ!

NL Dit accessoire moet worden gebruikt in combinatie met een CRUZ dakdragersysteem!

RU Данный аксессуар должен быть использован с багажной системой на крышу марки CRUZ!

EN This accessory must be used with CRUZ roof rack systems!

PL To wyposażenie musi być używane z systemami bagażnika dachowego firmy CRUZ!

GR Το αξεσουάρ αυτό θα πρέπει να χρησιμοποιείται αποκλειστικά στα συστήματα μπαρών της CRUZ!

FR Cet accessoire devra être utilisé avec les systèmes porte-charge CRUZ!

CZ Toto příslušenství musí být používáno s nosným systémem CRUZ!

TR Bu aksesuarlar mutlak CRUZ taşıma sistemleriyle kullanılmalıdır!

DE Dieses Zubehör muß mit einem CRUZ Trägersystem verwendet werden!

HU Ez a kiegészítő CRUZ rudakkal használható a csomagtartó rendszerekhez!

SI Dodatek naj se uporablja le z izdelki iz asortimana strešnih košar CRUZ!

PT Este accesorio deve ser utilizado com sistemas porta cargas CRUZ!

HR Ovi dodaci moraju biti korišteni uz CRUZ sistem krovnog nosača!

2. 

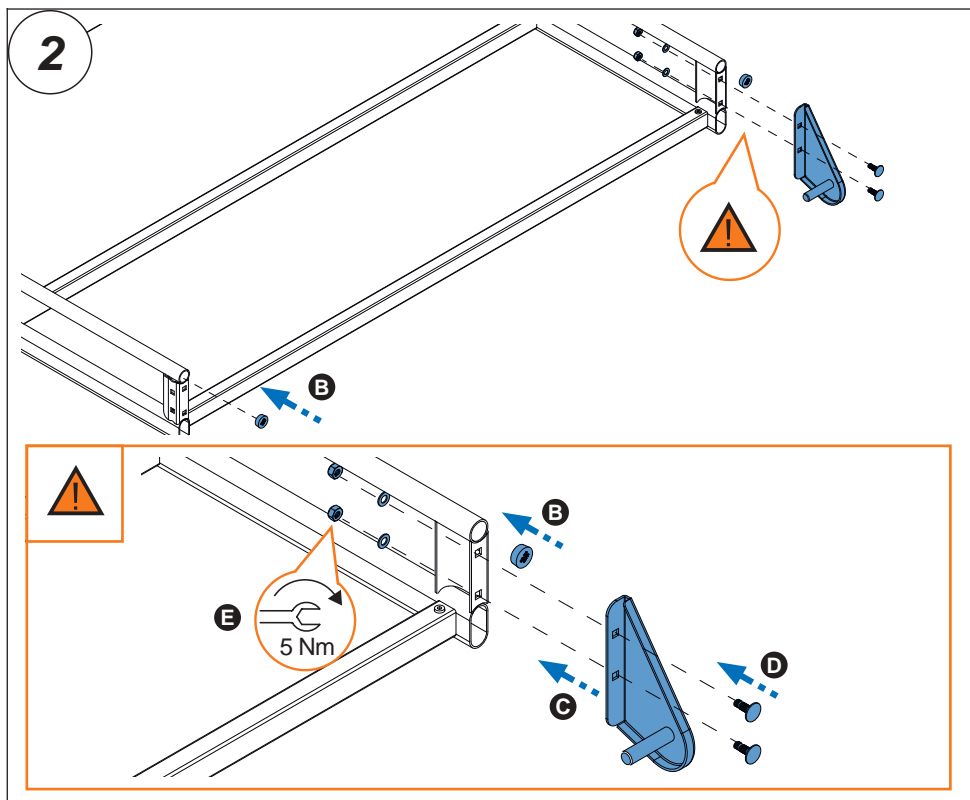
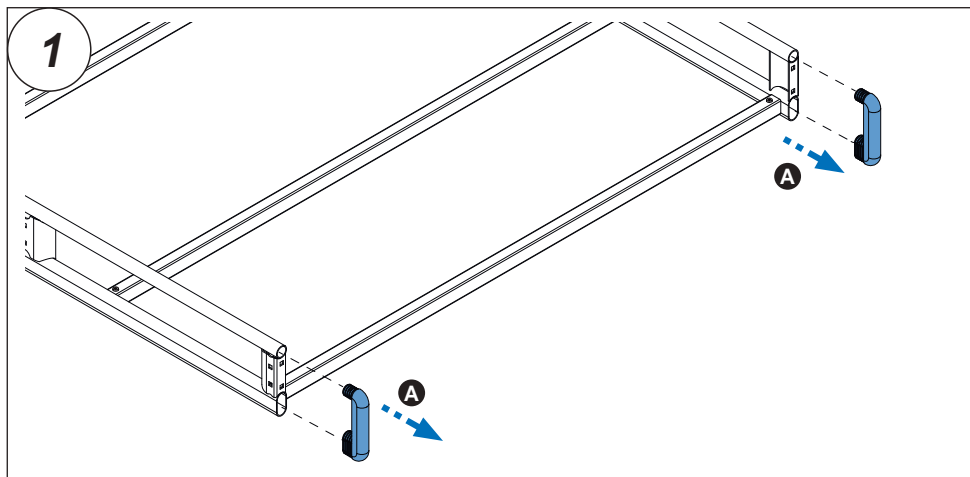

3. 

